



AVTECH ELECTROSYSTEMS LTD.

NANOSECOND WAVEFORM ELECTRONICS
SINCE 1975

P.O. BOX 265
OGDENSBURG, NY
U.S.A. 13669-0265

TEL: 888-670-8729 (USA & Canada) or +1-613-226-5772 (Intl)
FAX: 800-561-1970 (USA & Canada) or +1-613-226-2802 (Intl)

info@avtechpulse.com - <http://www.avtechpulse.com/>

BOX 5120, LCD MERIVALE
OTTAWA, ONTARIO
CANADA K2C 3H4

INSTRUCTIONS

MODELS AVRQ-2-B-PN-EVE and AVRQ-3-B

± 1 kV and ± 1.5 kV AMPLITUDE,

25 ns to 250 ns ADJUSTABLE RISE TIME,

PULSE GENERATORS FOR

COMMON MODE TRANSIENT IMMUNITY (CMTI) TESTS

SERIAL NUMBER: _____

WARRANTY

Avtech Electrosystems Ltd. warrants products of its manufacture to be free from defects in material and workmanship under conditions of normal use. If, within one year after delivery to the original owner, and after prepaid return by the original owner, this Avtech product is found to be defective, Avtech shall at its option repair or replace said defective item. This warranty does not apply to units which have been disassembled, modified or subjected to conditions exceeding the applicable specifications or ratings. This warranty is the extent of the obligation assumed by Avtech with respect to this product and no other warranty or guarantee is either expressed or implied.

TECHNICAL SUPPORT

Phone: 888-670-8729 (USA & Canada) or +1-613-226-5772 (Intl)

Fax: 800-561-1970 (USA & Canada) or +1-613-226-2802 (Intl)

E-mail: info@avtechpulse.com

World Wide Web: <http://www.avtechpulse.com>

TABLE OF CONTENTS

WARRANTY.....	2
TECHNICAL SUPPORT.....	2
TABLE OF CONTENTS.....	3
INTRODUCTION.....	5
MODEL NUMBER HISTORY.....	6
HIGH-VOLTAGE PRECAUTIONS.....	7
SPECIFICATIONS.....	8
EUROPEAN REGULATORY NOTES.....	9
EC DECLARATION OF CONFORMITY.....	9
DIRECTIVE 2002/95/EC (RoHS).....	9
DIRECTIVE 2002/96/EC (WEEE).....	9
INSTALLATION.....	11
VISUAL CHECK.....	11
POWER RATINGS.....	11
CONNECTION TO THE POWER SUPPLY.....	11
PROTECTION FROM ELECTRIC SHOCK.....	12
ENVIRONMENTAL CONDITIONS.....	12
FUSES.....	14
AC FUSE REPLACEMENT.....	14
DC FUSE REPLACEMENT.....	15
FUSE RATINGS.....	15
FRONT PANEL CONTROLS.....	16
REAR PANEL CONTROLS.....	18
GENERAL INFORMATION.....	21
BASIC PULSE CONTROL.....	21
TRIGGER MODES.....	22
GATING MODES.....	23
DUT INSTALLATION.....	24
SINGLE AND DUAL-CHANNEL PINOUTS.....	24
BASIC TEST ARRANGEMENT.....	27
TYPICAL WAVEFORMS.....	29
BASIC THEORY.....	29

AVAGO HCPL-2630.....	30
TRW 6N137.....	32
AVAGO HCPL-2601.....	33
QTC HCPL-2601.....	34
<i>SAFETY CONCERNS</i>	36
TURN OUTPUT OFF BEFORE ACCESSING DUT.....	36
AUTOMATIC TIMEOUT.....	36
OVERLOAD INDICATOR.....	36
<i>OPERATIONAL CHECK</i>	37
<i>PROTECTING YOUR INSTRUMENT</i>	40
USE HIGH-VOLTAGE CABLES, CONNECTORS, AND PROBES.....	40
SHORT-CIRCUIT PROTECTION.....	40
<i>MECHANICAL INFORMATION</i>	41
TOP COVER REMOVAL.....	41
RACK MOUNTING.....	41
<i>MAINTENANCE</i>	42
REGULAR MAINTENANCE.....	42
CLEANING.....	42
<i>PROGRAMMING YOUR PULSE GENERATOR</i>	43
KEY PROGRAMMING COMMANDS.....	43
ALL PROGRAMMING COMMANDS.....	45
<i>WIRING DIAGRAMS</i>	47
WIRING OF AC POWER.....	47
PCB 158M - LOW VOLTAGE POWER SUPPLY, 1/3.....	48
PCB 158M - LOW VOLTAGE POWER SUPPLY, 2/3.....	49
PCB 158M - LOW VOLTAGE POWER SUPPLY, 3/3.....	50
PCB 104D - KEYPAD / DISPLAY BOARD, 1/3.....	51
PCB 104D - KEYPAD / DISPLAY BOARD, 2/3.....	52
PCB 104D - KEYPAD / DISPLAY BOARD, 3/3.....	53
DUT WIRING.....	54
MAIN WIRING.....	55
<i>PERFORMANCE CHECK SHEET</i>	56

INTRODUCTION

The AVRQ-2-B-PN-EVE / AVRQ-3-B is designed to test the common mode transient immunity (CMTI) of opto-couplers.

The AVRQ-2-B-PN-EVE / AVRQ-3-B provides a zero-insertion-force (ZIF) socket that will accept standard 8-pin single-channel and dual-channel opto-couplers. A high-voltage pulse is applied to the floating input-side “ground” of the DUT. The output-side ground is connected to the instrument chassis earth ground. The device-under-test (DUT) ZIF socket is accessed from the rear-panel, through a hinged door. The high-voltage outputs are disabled when the door is open.

The high-voltage pulse amplitude may be set at -1.5 kV, -1.0 kV, +1.0 kV or +1.5 kV. This is the “AMP1” setting shown on the front panel. It may be set from the front-panel, or by using a command of the form “volt1 +1000”.

The output-side VCC voltage may be varied from +3.0V to +5.0V DC. This is the “AMP2” setting shown on the front panel. It may be set from the front-panel, or by using a command of the form “volt2 +5.0”.

The input-side LED bias current may be varied from 1 mA to 16 mA, or set at zero. This is the “OS2” setting shown on the front panel. It may be set from the front-panel, or by using a command of the form “curr:low2 10 mA”.

The rise time (measured 10%-90%) of the high-voltage pulse may be varied over the range of < 25 ns to > 250 ns. This is the “TR” setting shown on the front panel. It may be set from the front-panel, or by using a command of the form “pulse:transition 50 ns”. The rise time control is NOT calibrated, since it is strongly influenced by device capacitance and other parasitic effects. The actual rise time must be measured by the user, and it may differ significantly from the set value.

The output logic signal is “pulled-up” to VCC by an adjustable resistance in the range of 300 Ohms to 5 kilohms. This is the “RES” setting shown on the front panel. It may be set from the front-panel, or by using a command of the form “output:impedance 1000”.

The high-voltage pulse and the logic output of the DUT must be measured by the user, using suitable high-impedance oscilloscope probes. Coaxial cabling should not be used. Normally, the user will decrease the rise time of the high voltage pulse until logic-level “glitches” are observed on the logic output.

The AVRQ-2-B-PN-EVE / AVRQ-3-B features front panel keyboard and adjust knob control of the output pulse parameters along with a four line by 40-character backlit LCD display of the rise time, pulse width, pulse delay, and pulse repetition frequency. The instrument includes memory to store up to four complete instrument setups. The operator may use the front panel or the computer interface to store a complete “snapshot” of all key instrument settings, and recall this setup at a later time.

This instrument is intended for use in research, development, test and calibration laboratories by qualified personnel.

MODEL NUMBER HISTORY

The AVRQ-3-B was originally developed as a customized model, with the model number AVRQ-2-B-PN-EVE. It is now available as a standard model, AVRQ-3-B. The two model numbers refer to the same instrument, and either model number may be used when ordering, although the standard AVRQ-3-B is preferred.

HIGH-VOLTAGE PRECAUTIONS

 **CAUTION:** This instrument provides output voltages as high as 1500 Volts under normal operating conditions, and generates up to 1600V internally, so extreme caution must be employed when using this instrument. The instrument should only be used by individuals who are thoroughly skilled in high voltage laboratory techniques. The following precautions should always be observed:

1. Keep exposed high-voltage wiring to an absolute minimum.
2. Wherever possible, use shielded connectors and cabling.
3. Connect and disconnect loads and cables only when the instrument is turned off.
4. Keep in mind that all cables, connectors, oscilloscope probes, and loads must have an appropriate voltage rating.

Do not attempt any repairs on the instrument, beyond the fuse replacement procedures described in this manual. Contact Avtech technical support (see page 2 for contact information) if the instrument requires servicing.

SPECIFICATIONS

Model:	AVRQ-2-B-PN-EVE or AVRQ-3-B
GPIB and RS-232 control:	Yes.
HV Pulse Amplitude:	-1500V, -1000V, +1000V, or +1500V (+/- 5%)
VCC Amplitude:	+3.0V to +5.0V DC
LED Bias:	0 mA, or 1 mA to 16 mA
Logic pull-up:	300 to 5000 Ohms
Leading edge rise time ² : (10% - 90%):	< 25 ns to > 250 ns, variable. (Refers to the leading edge, which swings from 0 to -2000V).
Leading edge shape:	Linear, approximately. See the "Typical Waveforms" section of this manual.
Trailing edge fall time: (90% - 10%):	At least ten times greater than the rise time.
Trailing edge shape:	Exponential decay, approximately. See the "Typical Waveforms" section of this manual.
Pulse width:	1 μ s (measured between the start of the leading edge and the start of the falling edge)
PRF:	Internal trigger: 1 to 10 Hz External trigger: 0 to 10 Hz
Output protection:	Short-circuit protected.
Output enable timer:	The output is disabled automatically after 90 seconds of inactivity (i.e., unchanged pulse settings).
Propagation delay:	\leq 200 ns (Ext trig in to start of output pulse)
Jitter (Ext trig in to pulse out):	\pm 200 ps \pm 0.03% of sync delay
Trigger required (ext trig mode):	TTL levels (0 and +3V to +5V), 50 ns or wider
Sync delay:	Variable 0 to \pm 1.0 seconds
Sync output:	TTL levels (0 and +3V to +5V), 100 ns, will drive 50 Ohm loads
Gate input:	Synchronous, active high or low, switchable. Suppresses triggering when active.
Connectors:	LOGIC OUT: BNC, rear panel. DIFF PROBE: two-pin 0.1" header HV PULSE: BNC, rear panel. Trig, Gate: BNC, rear-panel. Sync: BNC, front-panel.
Power requirements:	100 - 240 Volts, 50 - 60 Hz
Dimensions: (H x W x D)	145 mm x 430 mm x 475 mm (5.7" x 17" x 18.8")
Chassis material:	cast aluminum frame and handles, blue vinyl on aluminum cover plates
Temperature range:	+5°C to +40°C

EUROPEAN REGULATORY NOTES

EC DECLARATION OF CONFORMITY

We Avtech Electrosystems Ltd.
P.O. Box 5120, LCD Merivale
Ottawa, Ontario
Canada K2C 3H4

declare that this pulse generator meets the intent of Directive 89/336/EEC for Electromagnetic Compatibility. Compliance pertains to the following specifications as listed in the official Journal of the European Communities:

EN 50081-1 Emission

EN 50082-1 Immunity

and that this pulse generator meets the intent of the Low Voltage Directive 72/23/EEC as amended by 93/68/EEC. Compliance pertains to the following specifications as listed in the official Journal of the European Communities:

EN 61010-1:2001 Safety requirements for electrical equipment for measurement, control, and laboratory use



DIRECTIVE 2002/95/EC (RoHS)

This instrument is exempt from Directive 2002/95/EC of the European Parliament and of the Council of 27 January 2003 on the Restriction of the use of certain Hazardous Substances (RoHS) in electrical and electronic equipment. Specifically, Avtech instruments are considered "Monitoring and control instruments" (Category 9) as defined in Annex 1A of Directive 2002/96/EC. The Directive 2002/95/EC only applies to Directive 2002/96/EC categories 1-7 and 10, as stated in the "Article 2 - Scope" section of Directive 2002/95/EC.

DIRECTIVE 2002/96/EC (WEEE)

European customers who have purchased this equipment directly from Avtech will have completed a "WEEE Responsibility Agreement" form, accepting responsibility for

WEEE compliance (as mandated in Directive 2002/96/EC of the European Union and local laws) on behalf of the customer, as provided for under Article 9 of Directive 2002/96/EC.

Customers who have purchased Avtech equipment through local representatives should consult with the representative to determine who has responsibility for WEEE compliance. Normally, such responsibilities will lie with the representative, unless other arrangements (under Article 9) have been made.

Requirements for WEEE compliance may include registration of products with local governments, reporting of recycling activities to local governments, and financing of recycling activities.

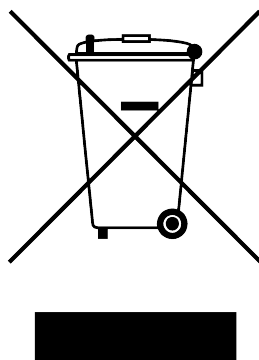

INSTALLATION

VISUAL CHECK

After unpacking the instrument, examine to ensure that it has not been damaged in shipment. Visually inspect all connectors, knobs, liquid crystal displays (LCDs), and the handles. Confirm that a power cord, a GPIB cable, and two instrumentation manuals (this manual and the “Programming Manual for -B Instruments”) are with the instrument. If the instrument has been damaged, file a claim immediately with the company that transported the instrument.

POWER RATINGS

This instrument is intended to operate from 100 - 240 V, 50 - 60 Hz.

The maximum power consumption is 57 Watts. Please see the “FUSES” section for information about the appropriate AC and DC fuses.

This instrument is an “Installation Category II” instrument, intended for operation from a normal single-phase supply.

CONNECTION TO THE POWER SUPPLY

An IEC-320 three-pronged recessed male socket is provided on the back panel for AC power connection to the instrument. One end of the detachable power cord that is supplied with the instrument plugs into this socket. The other end of the detachable power cord plugs into the local mains supply. Use only the cable supplied with the instrument. The mains supply must be earthed, and the cord used to connect the instrument to the mains supply must provide an earth connection. (The supplied cord does this.)

 Warning: Failure to use a grounded outlet may result in injury or death due to electric shock. This product uses a power cord with a ground connection. It must be connected to a properly grounded outlet. The instrument chassis is connected to the ground wire in the power cord.

The table below describes the power cord that is normally supplied with this instrument, depending on the destination region:

Destination Region	Description	Manufacturer	Part Number
Continental Europe	European CEE 7/7 "Schuko" 230V, 50Hz	Qualtek (http://www.qualtekusa.com)	319004-T01
United Kingdom	BS 1363, 230V, 50Hz	Qualtek (http://www.qualtekusa.com)	370001-E01
Switzerland	SEV 1011, 2 30V, 50Hz	Volex (http://www.volex.com)	2102H-C3-10
Israel	SI 32, 220V, 50Hz	Volex (http://www.volex.com)	2115H-C3-10
North America, and all other areas	NEMA 5-15, 120V, 60 Hz	Qualtek (http://www.qualtekusa.com)	312007-01

PROTECTION FROM ELECTRIC SHOCK

 Operators of this instrument must be protected from electric shock at all times. The owner must ensure that operators are prevented access and/or are insulated from every connection point. In some cases, connections must be exposed to potential human contact. Operators must be trained to protect themselves from the risk of electric shock. This instrument is intended for use by qualified personnel who recognize shock hazards and are familiar with safety precautions required to avoid possibly injury. In particular, operators should:

1. Keep exposed high-voltage wiring to an absolute minimum.
2. Wherever possible, use shielded connectors and cabling.
3. Connect and disconnect loads and cables only when the instrument is turned off.
4. Keep in mind that all cables, connectors, oscilloscope probes, and loads must have an appropriate voltage rating.
5. Do not attempt any repairs on the instrument, beyond the fuse replacement procedures described in this manual. Contact Avtech technical support (see page 2 for contact information) if the instrument requires servicing. Service is to be performed solely by qualified service personnel.

ENVIRONMENTAL CONDITIONS

This instrument is intended for use under the following conditions:

1. indoor use;
2. altitude up to 2 000 m;
3. temperature 5 °C to 40 °C;

4. maximum relative humidity 80 % for temperatures up to 31 °C decreasing linearly to 50 % relative humidity at 40 °C;
5. Mains supply voltage fluctuations up to ± 10 % of the nominal voltage;
6. no pollution or only dry, non-conductive pollution.

FUSES

This instrument contains four fuses. All are accessible from the rear-panel. Two protect the AC prime power input, and two protect the internal DC power supplies. The locations of the fuses on the rear panel are shown in the figure below:

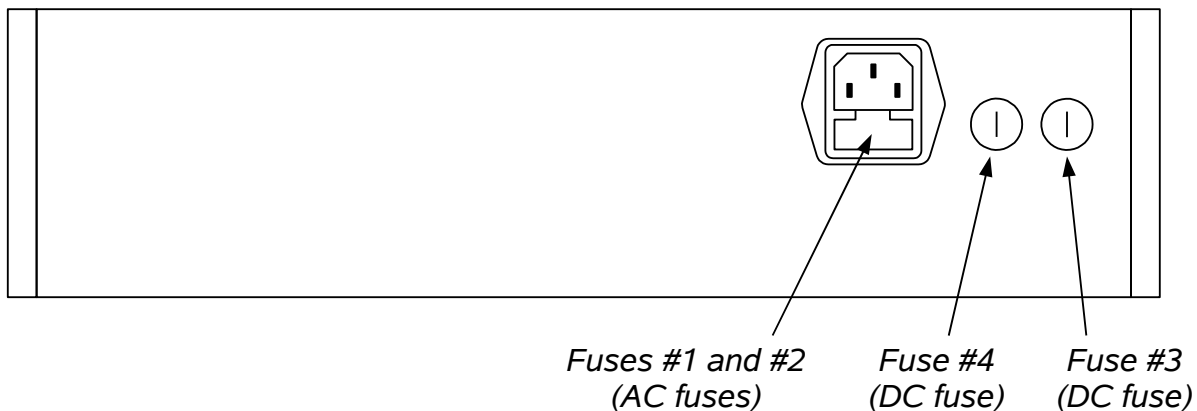

AC FUSE REPLACEMENT

To physically access the AC fuses, the power cord must be detached from the rear panel of the instrument. The fuse drawer may then be extracted using a small flat-head screwdriver, as shown below:

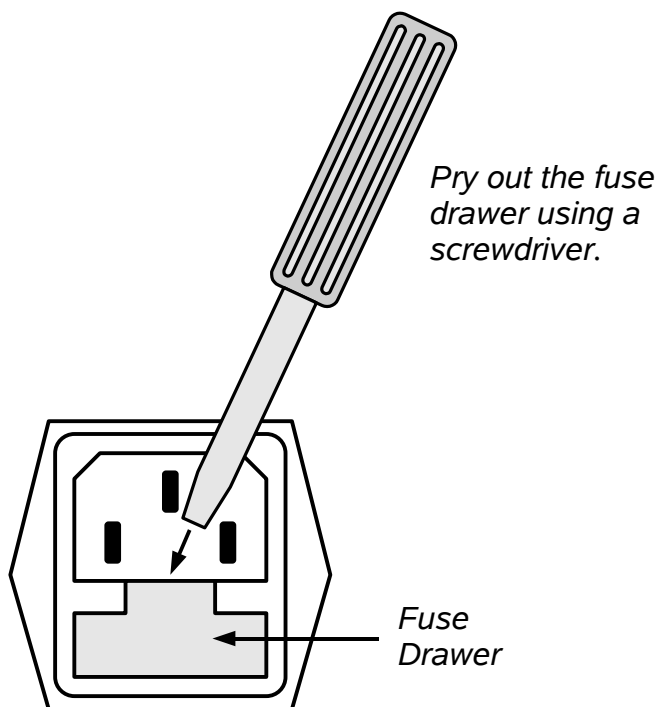

DC FUSE REPLACEMENT

The DC fuses may be replaced by inserting the tip of a flat-head screwdriver into the fuse holder slot, and rotating the slot counter-clockwise. The fuse and its carrier will then pop out.

FUSE RATINGS

The following table lists the required fuses:

Fuses	Nominal Mains Voltage	Rating	Case Size	Recommended Replacement Part	
				Littelfuse Part Number	Digi-Key Stock Number
#1, #2 (AC)	100-240V	0.5A, 250V, Time-Delay	5×20 mm	0218.500HXP	F2416-ND
#3 (DC)	N/A	1.6A, 250V, Time-Delay	5×20 mm	021801.6HXP	F2424-ND
#4 (DC)	N/A	0.5A, 250V, Time-Delay	5×20 mm	0218.500HXP	F2416-ND

The recommended fuse manufacturer is Littelfuse (<http://www.littelfuse.com>).

Replacement fuses may be easily obtained from Digi-Key (<http://www.digikey.com>) and other distributors.

FRONT PANEL CONTROLS

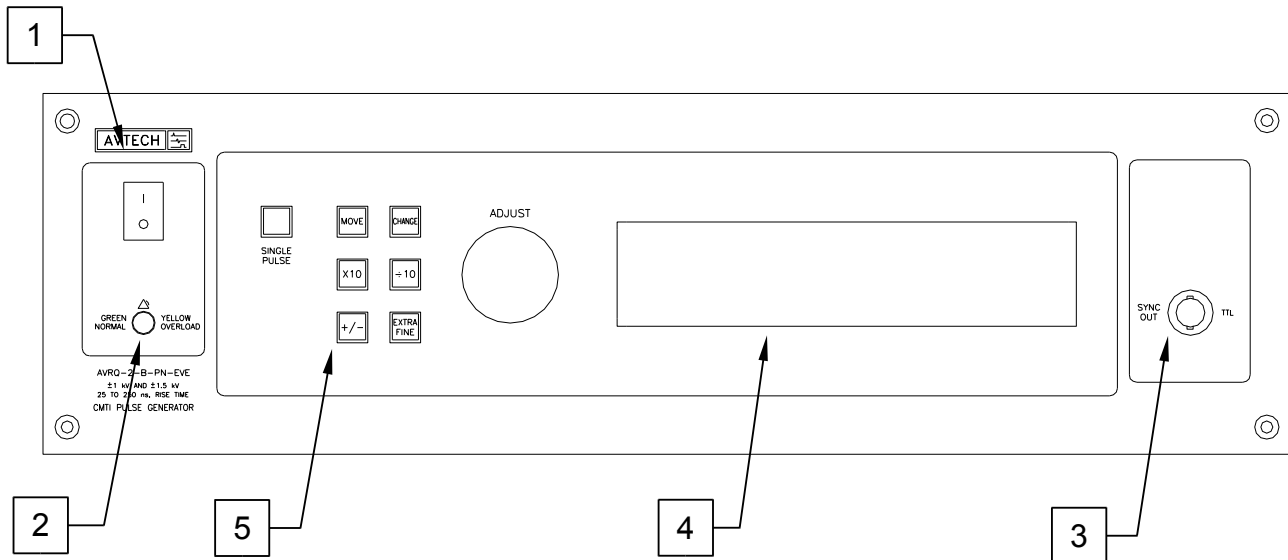

1. **POWER Switch.** This is the main power switch. When turning the instrument on, there may be a delay of several seconds before the instrument appears to respond.
2. **OVERLOAD Indicator.** When the instrument is powered, this indicator is normally green, indicating normal operation. If this indicator is yellow, an internal automatic overload protection circuit has been tripped. If the unit is overloaded (by operating at an exceedingly high duty cycle or by operating into a very low impedance), the protective circuit will disable the output of the instrument and turn the indicator light yellow. The light will stay yellow (i.e. output disabled) for about 5 seconds after which the instrument will attempt to re-enable the output (i.e. light green) for about 1 second. If the overload condition persists, the output will be disabled again (i.e. light yellow) for another 5 seconds. If the overload condition has been removed, the instrument will resume normal operation.

This overload indicator may flash yellow briefly at start-up. This is not a cause for concern.

3. **SYNC OUT.** This connector supplies a SYNC output that can be used to trigger other equipment, particularly oscilloscopes. This signal leads (or lags) the main output by a duration set by the "DELAY" controls and has an approximate amplitude of +3 Volts to $R_L > 1 \text{ k}\Omega$ with a pulse width of approximately 100 ns.
4. **LIQUID CRYSTAL DISPLAY (LCD).** This LCD is used in conjunction with the keypad to change the instrument settings. Normally, the main menu is displayed, which lists the key adjustable parameters and their current values. The "Programming Manual for -B Instruments" describes the menus and submenus in detail.

5. KEYPAD.

Control Name	Function
MOVE	This moves the arrow pointer on the display.
CHANGE	This is used to enter the submenu, or to select the operating mode, pointed to by the arrow pointer.
×10	If one of the adjustable numeric parameters is displayed, this increases the setting by a factor of ten.
÷10	If one of the adjustable numeric parameters is displayed, this decreases the setting by a factor of ten.
+/-	If one of the adjustable numeric parameters is displayed, and this parameter can be both positive or negative, this changes the sign of the parameter.
EXTRA FINE	This changes the step size of the ADJUST knob. In the extra-fine mode, the step size is twenty times finer than in the normal mode. This button switches between the two step sizes.
ADJUST	This large knob adjusts the value of any displayed numeric adjustable values, such as frequency, pulse width, etc. The adjust step size is set by the "EXTRA FINE" button. When the main menu is displayed, this knob can be used to move the arrow pointer.

REAR PANEL CONTROLS

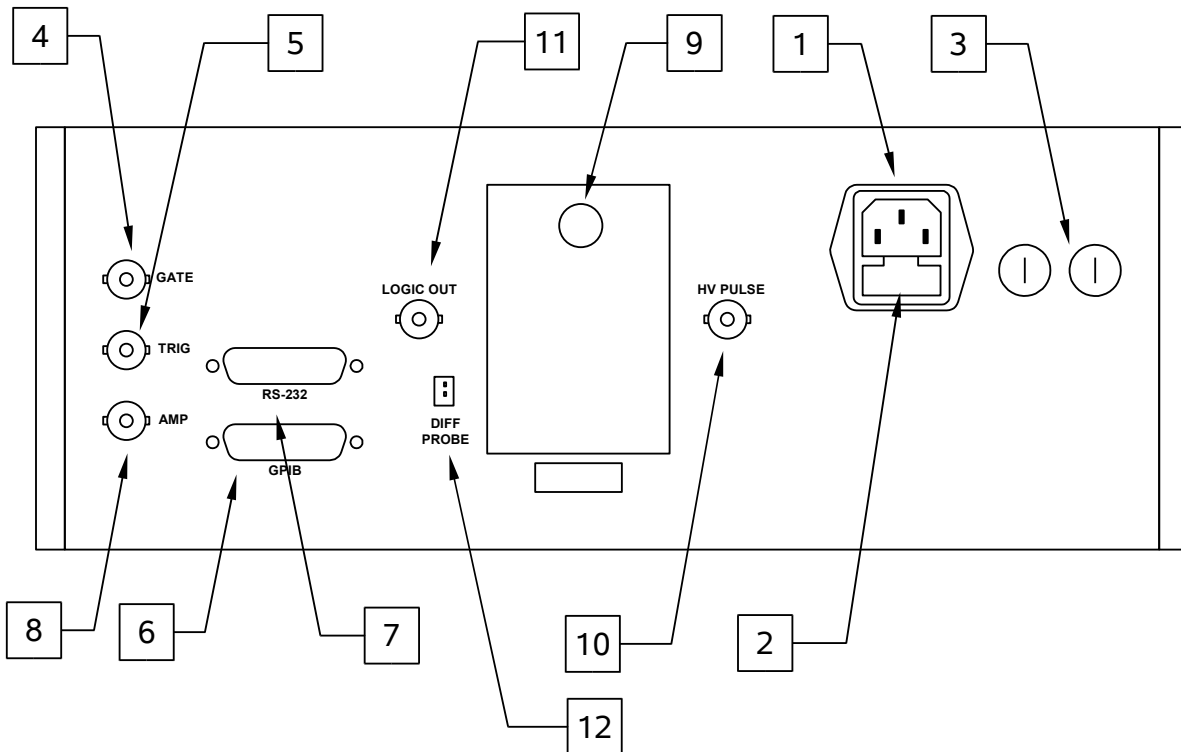

1. AC POWER INPUT. An IEC-320 C14 three-pronged recessed male socket is provided on the back panel for AC power connection to the instrument. One end of the detachable power cord that is supplied with the instrument plugs into this socket.
2. AC FUSE DRAWER. The two fuses that protect the AC input are located in this drawer. Please see the “FUSES” section of this manual for more information.
3. DC FUSES. These two fuses protect the internal DC power supplies. Please see the “FUSES” sections of this manual for more information.
4. GATE. This TTL-level (0 and +5V) logic input can be used to gate the triggering of the instrument. This input can be either active high or active low, depending on the front panel settings or programming commands. (The instrument triggers normally when this input is unconnected). When set to active high mode, this input is pulled-down to ground by a 1 k Ω resistor. When set to active low mode, this input is pulled-up to +5V by a 1 k Ω resistor.
5. TRIG. This TTL-level (0 and +5V) logic input can be used to trigger the instrument, if the instrument is set to triggering externally. The instrument triggers on the rising edge of this input. The input impedance of this input is 1 k Ω . (Depending on the length of cable attached to this input, and the source driving it, it may be desirable to add a coaxial 50 Ohm terminator to this input to provide a proper transmission line termination. The Pasternack (www.pasternack.com) PE6008-50 BNC feed-thru 50

Ohm terminator is suggested for this purpose.)

6. GPIB Connector. A standard GPIB cable can be attached to this connector to allow the instrument to be computer-controlled. See the “Programming Manual for -B Instruments” for more details on GPIB control.
7. RS-232 Connector. A standard serial cable with a 25-pin male connector can be attached to this connector to allow the instrument to be computer-controlled. See the “Programming Manual for -B Instruments” for more details on RS-232 control.
8. AMP Connector. Not used. No internal connection.
9. DUT Door. This is the door that provides access to the DUT socket. To open it, pull on the chrome knob. When closed, the door is held latched in place magnetically.

The high voltage output is automatically disabled when the DUT door is opened. The door must be closed during tests.

The layout of the DUT socket is discussed in the “DUT Socket” section.

10. HV PULSE CONNECTOR. The BNC connector provides access to the high voltage (± 1 kV or ± 1.5 kV) pulse that is applied to the DUT, for monitoring purposes. This signal must be observed on an oscilloscope to accurately measure the dV/dt rate of the high voltage pulse.

A Tektronix P5100 high-voltage probe with the 013-0291-00 probe-tip-to-BNC adapter should be used to connect to this output.

 CAUTION: Voltages as high as 1.5 kV may be present on the center conductor of this output connector. Avoid touching this conductor. Connect to this connector using a Tektronix P5100 high-voltage probe with the 013-0291-00 probe-tip-to-BNC adapter, to ensure that the center conductor is not exposed.

 DO NOT CONNECT THIS OUTPUT DIRECTLY TO AN OSCILLOSCOPE. The oscilloscope will be damaged by the high voltages. Use a Tektronix P5100 high-voltage probe with the 013-0291-00 probe-tip-to-BNC adapter.

 DO NOT CONNECT COAXIAL CABLING TO THIS OUTPUT. The capacitance of the cabling will reduce the dV/dt rates noticeably.

11. LOGIC OUT Connector. This BNC connector connects internally to the logic output of the DUT. This is the output that is monitored for “glitches” caused by high dV/dt rates on the common mode voltage. An oscilloscope probe with a probe-tip-to-BNC adapter should be connected to this output. (The Tektronix P6139A low-voltage probe with the 013-0254-00 probe-tip-to-BNC adapter may be suitable).

 DO NOT CONNECT COAXIAL CABLING TO THIS OUTPUT. The capacitance of

the cabling will distort the measurements.

The DIFF PROBE output can be used instead of the LOGIC OUT connector, if desired. They are both connected to the same point internally.

12. DIFF OUT Connector. The LOGIC OUT connector described above is referenced to chassis ground. This can cause some ringing on the output. The ringing will not normally confuse a human operator, but it may confused automatic measurement systems.

To avoid this problem, the two-pin DIFF OUT connector is provided. It will mate to the Tektronix P6246 differential probe. This will normally provide slightly “cleaner” output signals than the LOGIC OUT connector, since the ground noise will be subtracted from the signal output. When using the differential probe, install the probe so that the “-” side is on the top, and the “+” side is on the bottom.

The use of the DIFF OUT connector is optional.

GENERAL INFORMATION

BASIC PULSE CONTROL

This instrument can be triggered by its own internal clock or by an external TTL trigger signal. In either case, two output channels respond to the trigger: HV PULSE and SYNC. The HV PULSE channel is the signal that is applied to the DUT. Its amplitude is variable. The SYNC pulse is a fixed-width TTL-level reference pulse used to trigger oscilloscopes or other measurement systems. When the delay is set to a positive value the SYNC pulse precedes the HV PULSE pulse. When the delay is set to a negative value the SYNC pulse follows the HV PULSE pulse.

These pulses are illustrated below, assuming internal triggering, a positive delay, and positive amplitude:

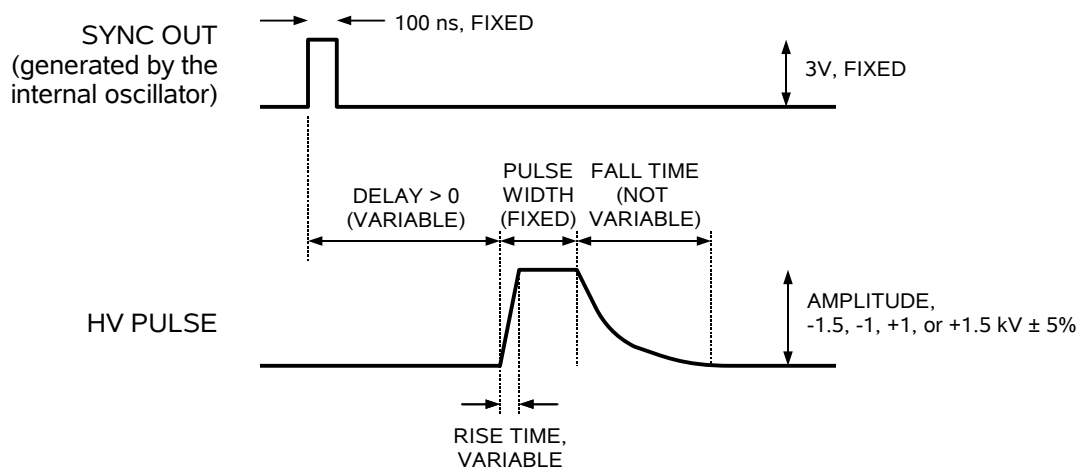

If the delay is negative, the order of the SYNC and OUT pulses is reversed:

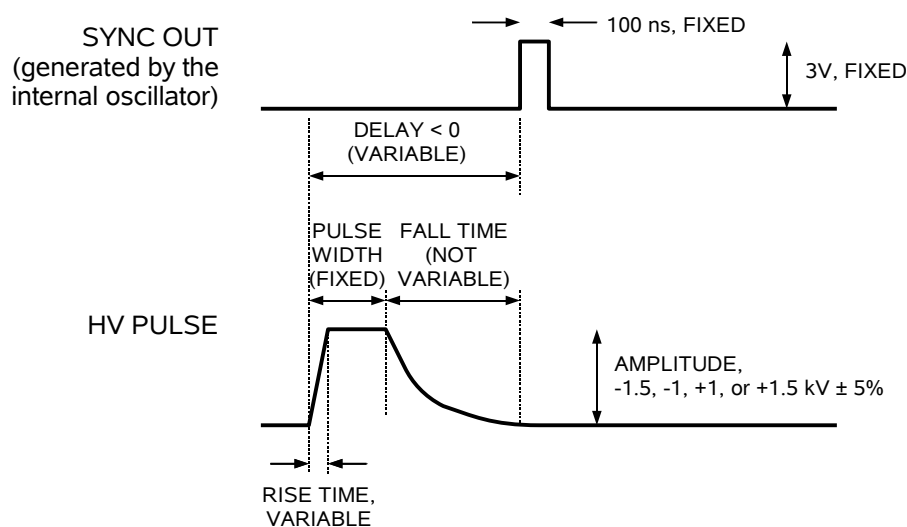

The next figure illustrates the relationship between the signals when an external TTL-level trigger is used:

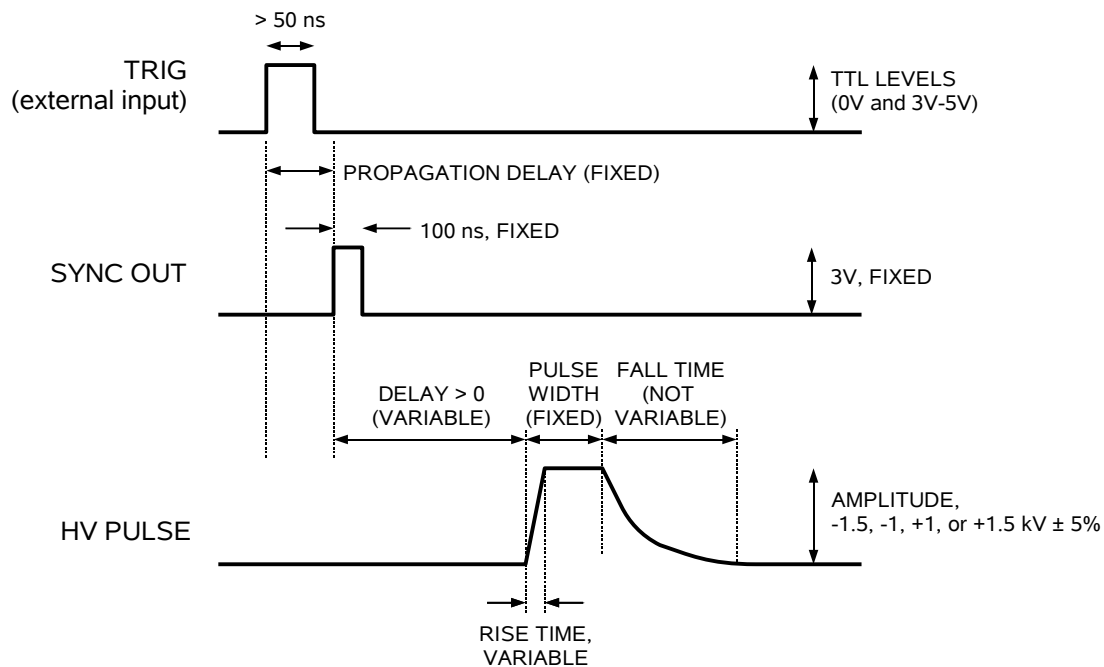

As before, if the delay is negative, the order of the SYNC and OUT pulses is reversed.

The delay, pulse width, and frequency (when in the internal mode), of the OUT pulse can be varied with front panel controls or via the GPIB or RS-232 computer interfaces.

TRIGGER MODES

This instrument has four trigger modes:

- Internal Trigger: the instrument controls the trigger frequency, and generates the clock internally.
- External Trigger: the instrument is triggered by an external TTL-level clock on the back-panel TRIG connector.
- Manual Trigger: the instrument is triggered by the front-panel "SINGLE PULSE" pushbutton.
- Hold Trigger: the instrument is set to not trigger at all.

These modes can be selected using the front panel trigger menu, or by using the appropriate programming commands. (See the “Programming Manual for -B Instruments” for more details.)

GATING MODES

Triggering can be suppressed by a TTL-level signal on the rear-panel GATE connector. The instrument can be set to stop triggering when this input high or low, using the front-panel gate menu or the appropriate programming commands. This input can also be set to act synchronously or asynchronously. When set to asynchronous mode, the GATE will disable the output immediately. Output pulses may be truncated. When set to synchronous mode, the output will complete the full pulse width if the output is high, and then stop triggering. No pulses are truncated in this mode.

DUT INSTALLATION

SINGLE AND DUAL-CHANNEL PINOUTS

The AVRQ-2-B-PN-EVE / AVRQ-3-B can accept 8-pin single-channel or dual-channel opto-couplers with the pinouts shown below:

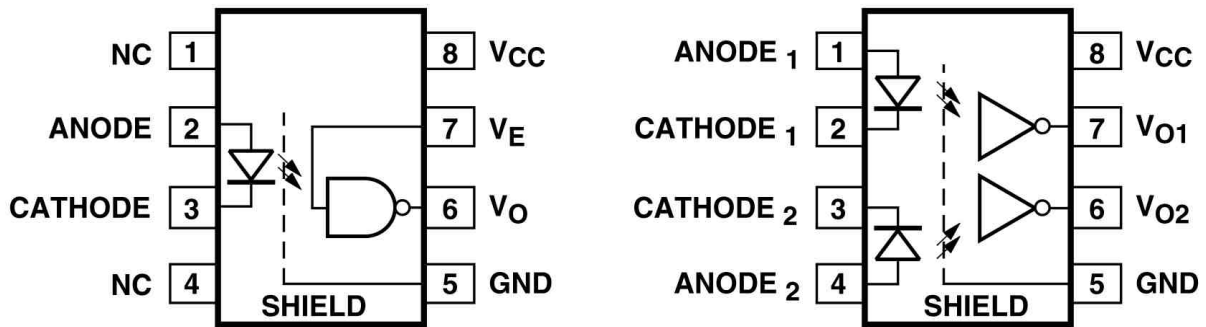

To install the DUT, locate the rear-panel DUT door, and open it, as shown below:

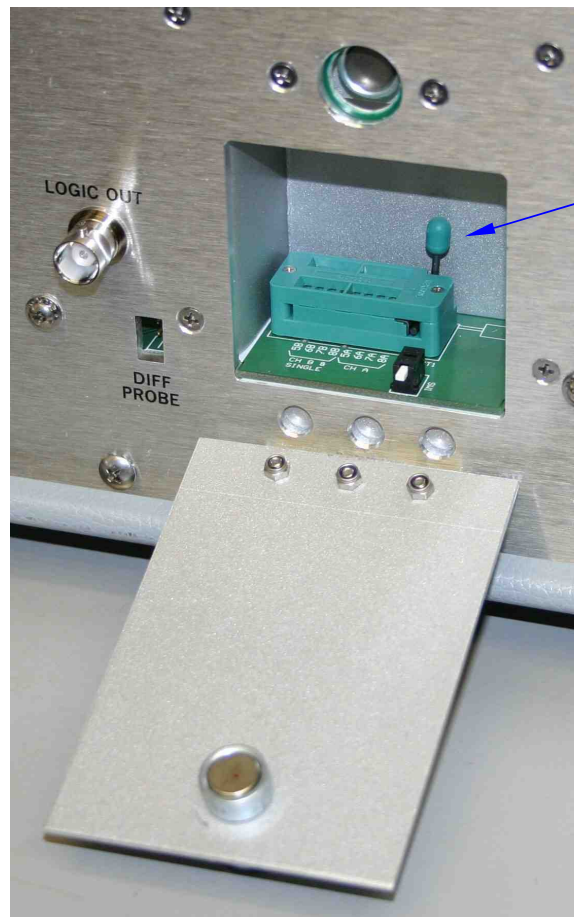

ZIF socket lever:
Up = Unlocked
Down = Locked

The outputs are automatically disabled when the DUT door is open. When testing single-channel devices, or channel “2” or “B” of a dual-channel device, the DUT should be installed in the leftmost position, shown below:



Pin numbers
are shown in
blue.

*To test a Single-Channel Device, or
Channel “2” or “B” of a Dual-Channel Device*

The rightmost position is used to test channel “1” or “A” of a dual-channel device, as shown below:



Pin numbers
are shown in
blue.

*To test
Channel "1" or "A" of a Dual-Channel Device*

Once the DUT is in the correct position, lower the ZIF lever into position to lock the device, and close the door.

BASIC TEST ARRANGEMENT

The figure below shows basic test arrangement for the AVRQ-2-B-PN-EVE / AVRQ-3-B, when the single-ended LOGIC OUT output is used, is shown below:

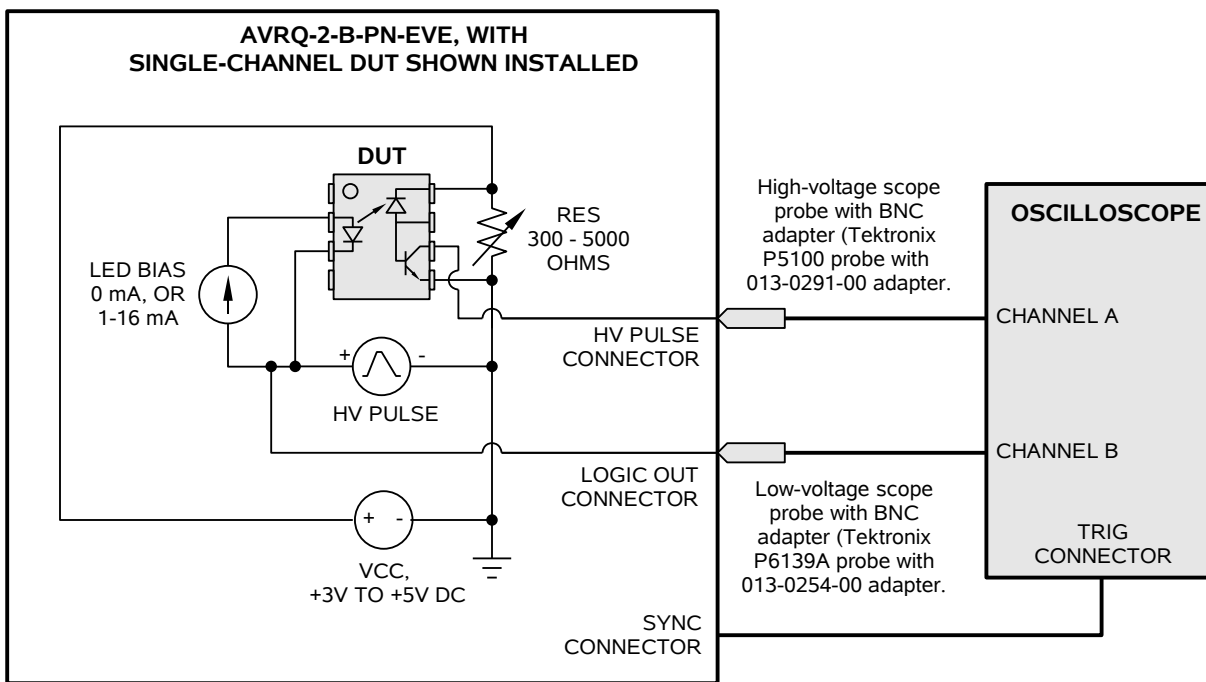

Alternatively, a differential probe may be used to monitor the logic output, giving a slightly different arrangement:

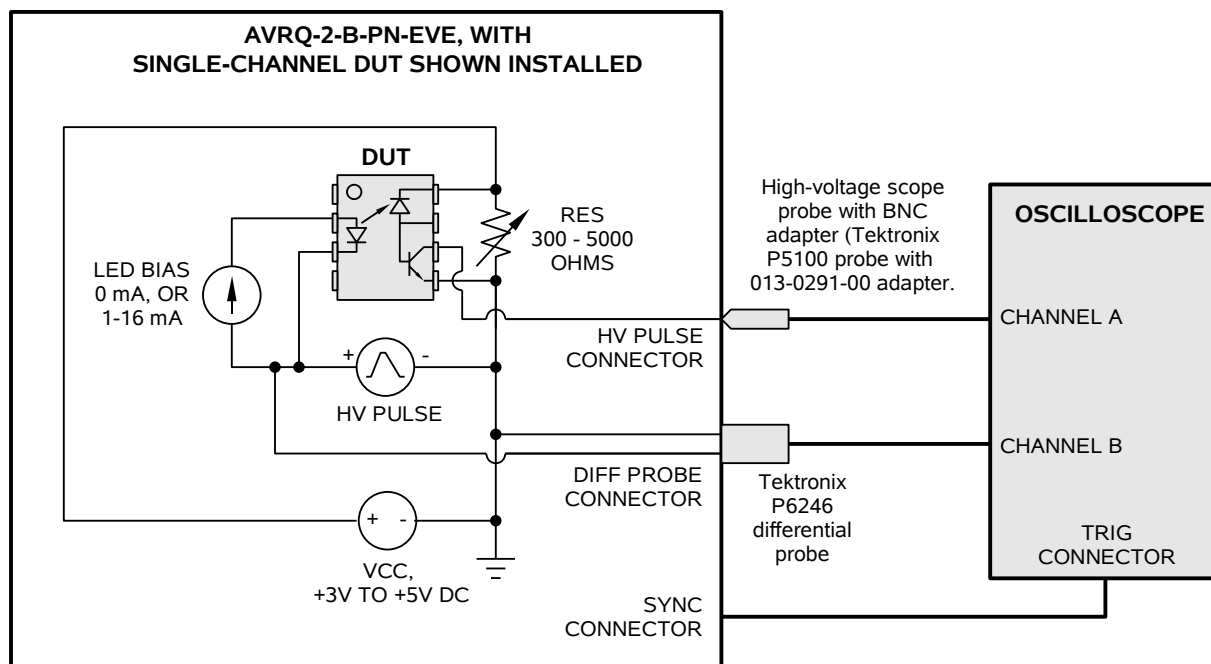

Coaxial cabling should only be used to connect the AVRQ-2-B-PN-EVE / AVRQ-3-B SYNC output to the oscilloscope trigger input. It should not be used anywhere else in the test system. The HV PULSE and LOGIC OUT / DIFF PROBE outputs should be measured using oscilloscope probes, without intervening cabling.

 Caution: The HV PULSE oscilloscope probe must be rated for operation at 1.5 kV (pulsed) or higher. Factory tests are conducted using a Tektronix P5100 probe, which has a 2.5 kV peak rating and a 1000:1 division ratio. (Remember to adjust the compensation of the probe to match your oscilloscope input.)

With the Tektronix P5100 high-voltage probe with the 013-0291-00 adapter and the Tektronix P6246 differential probe installed, the rear panel will look like:



When using the differential probe, install the probe so that the “-” side is on the top, and the “+” side is on the bottom.

TYPICAL WAVEFORMS

BASIC THEORY

The instrument will normally be set to test the DUT twice – once for a positive-going amplitude, and once for a negative-going amplitude.

With the HV PULSE amplitude (AMP1) set to +1 kV or +1.5 kV, the LED bias current (OS2) will normally be set 0 mA, to generate the waveforms shown below. (Under these conditions, a negative-going glitch will be generated by in response to the positive-going HV PULSE, making it clear that the glitch is due to the optocoupler output, and not due to capacitive coupling.)

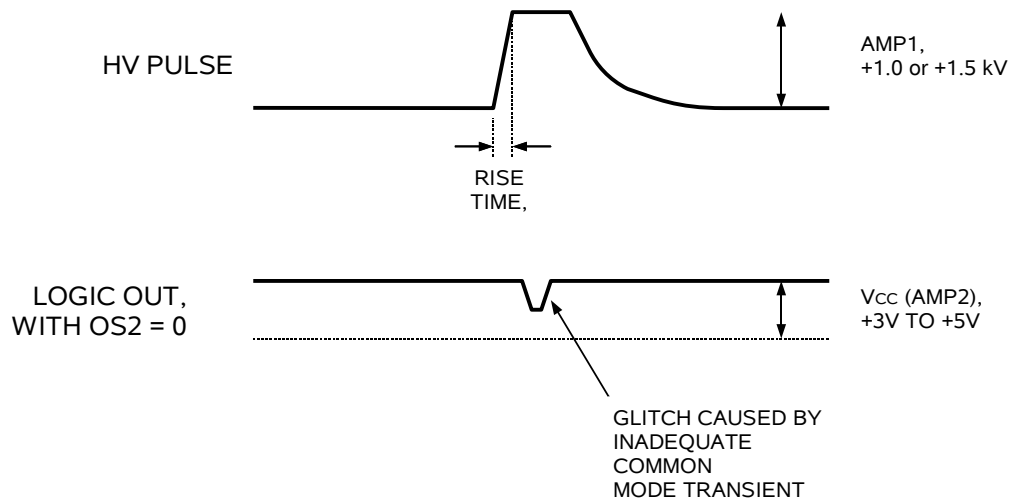

With the HV PULSE amplitude (AMP1) set to -1 kV or -1.5 kV, the LED bias current (OS2) will normally be set at a non-zero current, to generate the waveforms shown below. (Under these conditions, the a positive-going glitch will be generated by in response to the negative-going HV PULSE, making it clear that the glitch is due to the optocoupler output, and not due to capacitive coupling.)

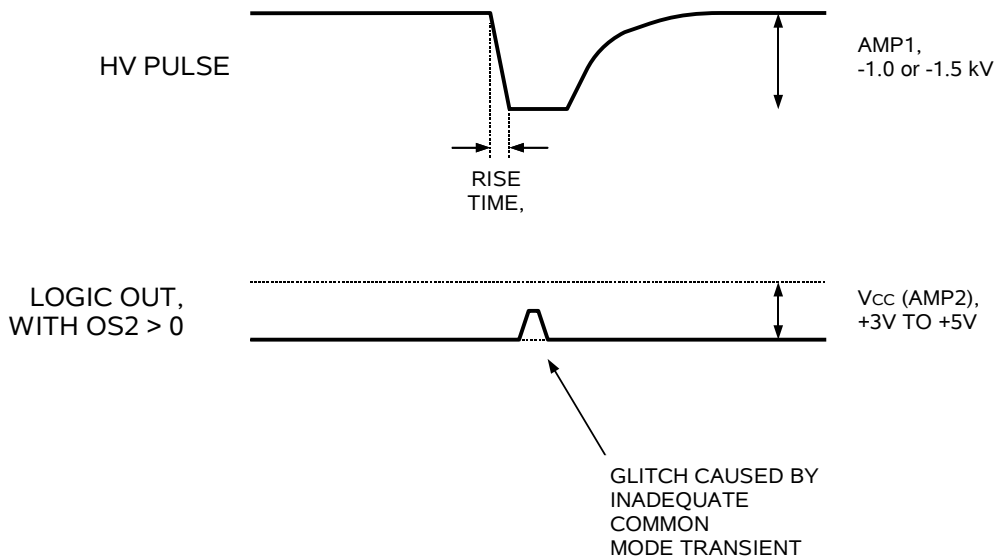

The other possible combinations of HV PULSE polarity and LED bias currents should not be used normally.

AVAGO HCPL-2630

The Avago HCPL-2630 is a dual-channel opto-coupler with a 5 kV/us minimum CMTI rating. With AMP1 = +1.0 kV, AMP2 = +5.0V, OS2 = 0 mA, and RES = 350Ω, Channel “A” of this opto-coupler (datecode 0647) generated the following DIFF PROBE and HV PULSE waveforms:

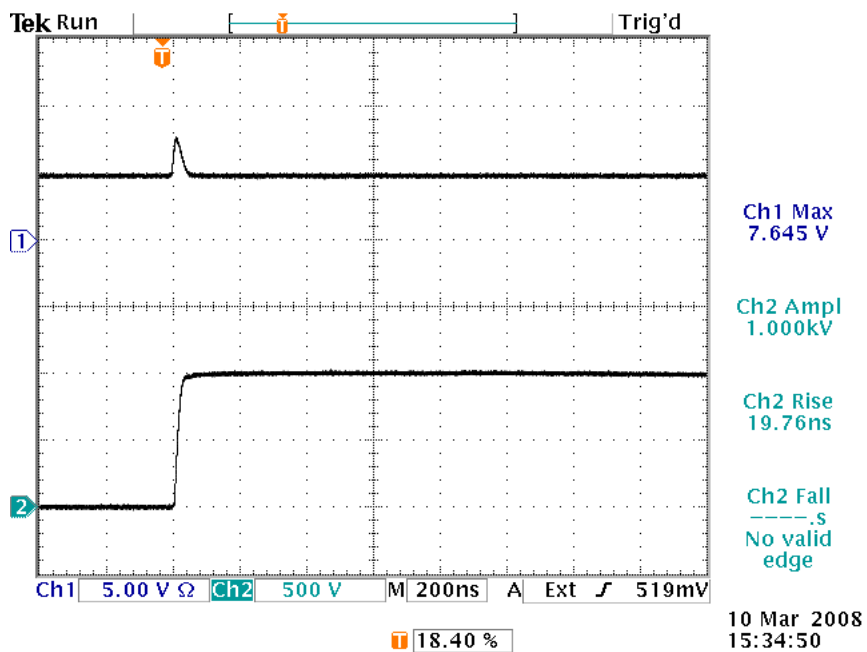

No negative-going glitch was observed even at the minimum rise time of 19.76 ns. The positive spike is a result of capacitive coupling within the instrument, and is not caused by the opto-coupler.

However, a glitch was observed when AMP1 was inverted to -1.0 kV, and OS2 was increased to 7.5 mA. The magnitude of the glitch reached 2 Volts for when the rise time was lowered to 70.69 ns:

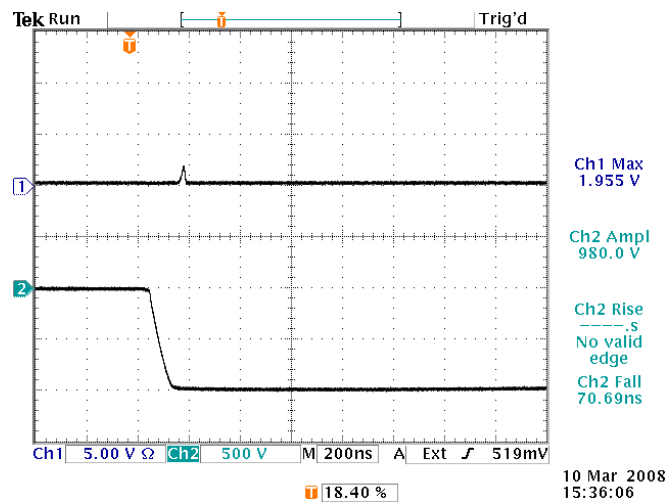

The magnitude of the glitch increased with shorter rise times:

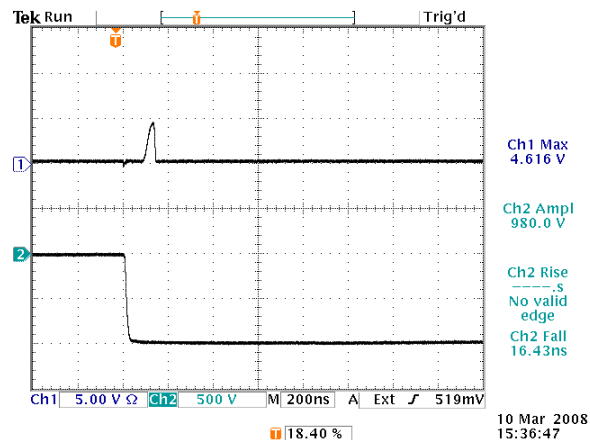

Using 2V as the threshold for a serious glitch, this gives us a CMTI rating of approximately $(1 \text{ kV} / 0.8) / 70.69 \text{ ns} = 17.7 \text{ kV} / \text{us}$. The rated CMTI for the HCPL-2630 is 5 kV / us.

Similar results were observed on the “B” channel – it operates normally with the slowest -1 kV pulse:

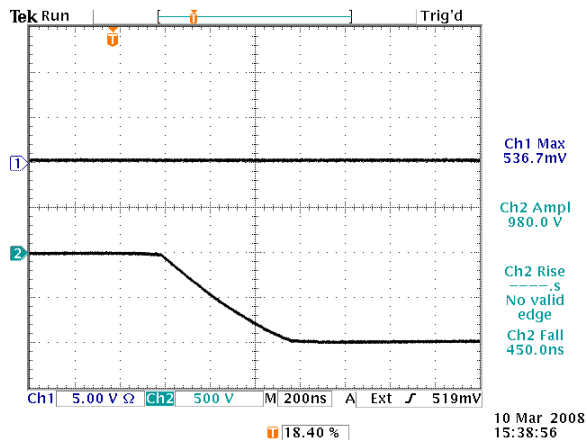

but the glitch reaches 2V for a rise time of 78.9 ns, giving $dV/dt = (1 \text{ kV} / 0.8) / 78.9 \text{ ns} = 15.8 \text{ kV} / \mu\text{s}$:

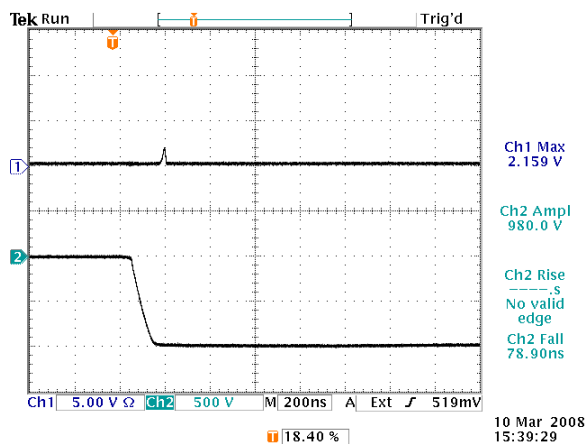

TRW 6N137

A much older single-channel device – the TRW 6N137 (datecode 8642) was also tested, since no glitches were generated with $AMP = +1 \text{ kV}$ for the Avago HCPL-2630. Under the same conditions ($+1 \text{ kV}$, 0 mA , $+5\text{V}$, 350 Ohms), the 6N137 did exhibit glitches, even with the maximum setting of the rise time:

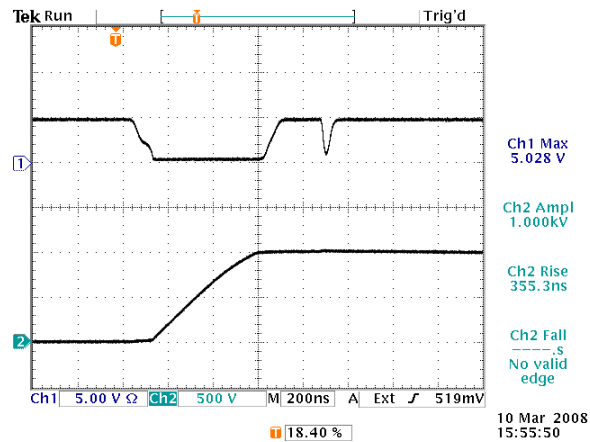

The -1 kV / 7.5 mA operation was similarly poor:

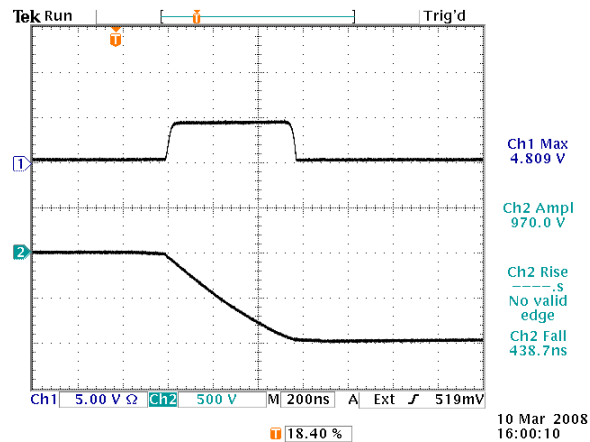

The TRW 6N137 was too slow to be fully characterized by the AVRQ-2-B-PN-EVE / AVRQ-3-B.

AVAGO HCPL-2601

The Avago HCPL-2601 is a single-channel opto-coupler with a 10 kV/us minimum CMTI rating. With AMP1 = +1.0 kV, AMP2 = +5.0V, OS2 = 0 mA, and RES = 350 Ω , this opto-coupler (datecode 0742) generated the following DIFF PROBE and HV PULSE waveforms:

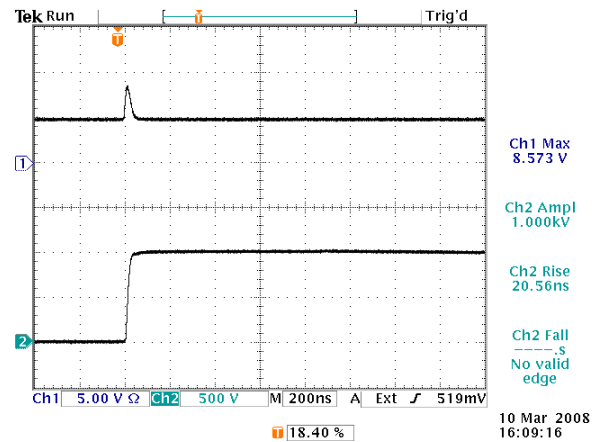

-1 kV / 7.5 mA operation gave:

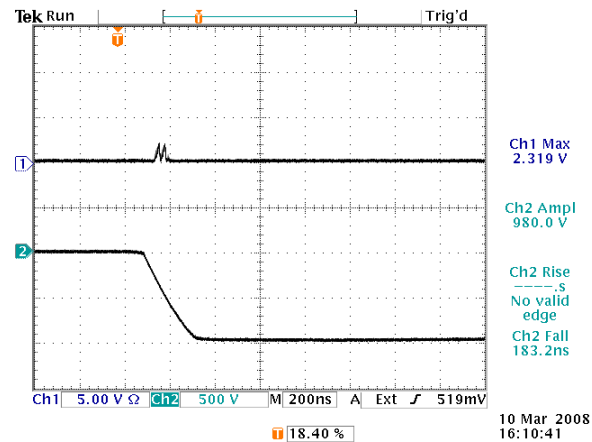

In other words, the Logic-High CMTI was $> (1 \text{ kV} / 0.8) / 20.56 \text{ ns} = 60.8 \text{ kV/us}$, but the Logic-Low CMTI was only $(1 \text{ kV} / 0.8) / 183.2 \text{ ns} = 6.8 \text{ kV / us}$.

QTC HCPL-2601

The QTC HCPL-2601 is nominally equivalent to the Avago HCPL-2601. With AMP1 = +1.0 kV, AMP2 = +5.0V, OS2 = 0 mA, and RES = 350Ω, this opto-coupler (datecode 9522) generated the following DIFF PROBE and HV PULSE waveforms:

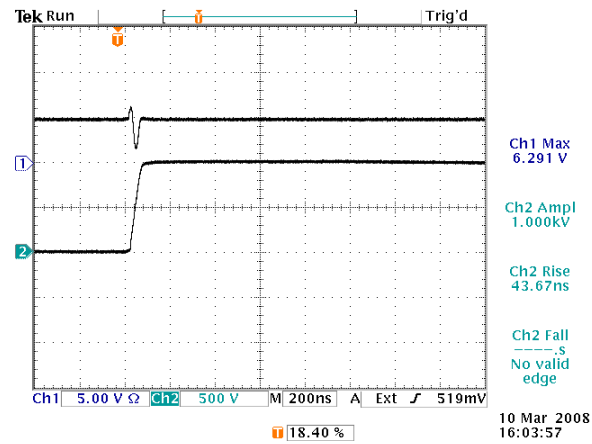

-1 kV / 7.5 mA operation gave:

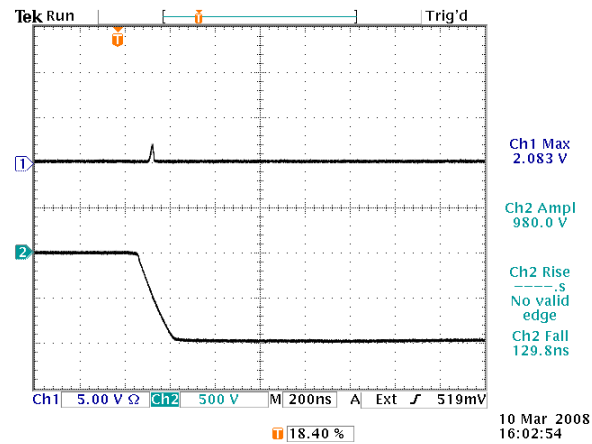

In other words, the Logic-High CMTI was $(1 \text{ kV} / 0.8) / 43.67 \text{ ns} = 28.6 \text{ kV/us}$, and the Logic-Low CMTI was $(1 \text{ kV} / 0.8) / 129.8 \text{ ns} = 9.6 \text{ kV} / \text{us}$.

Interestingly, the Logic-High CMTI was much worse than the equivalent Avago device, but the Logic-Low CMTI was better.

SAFETY CONCERNS

TURN OUTPUT OFF BEFORE ACCESSING DUT

Always turn the output off before opening the rear-panel DUT door, using the front panel menu or by computer command (“output off”).

If you do not disable the output first, the output will be automatically disabled by a sensor on the DUT door when it is opened. However, the user should not rely on this for safety purposes.

Always check that the front panel indicates that the output is “off” before touching the DUT ZIF socket.

AUTOMATIC TIMEOUT

The output is disabled automatically after 90 seconds of inactivity (i.e., unchanged pulse settings). The timer resets each time a pulse parameter (amplitude, rise time, etc) is changed.

OVERLOAD INDICATOR

The front-panel “overload” indicator should always glow green, and never amber (except briefly when the instrument is first turned on).

If the overload indicator becomes active (amber), stop using the instrument immediately.

OPERATIONAL CHECK

This section describes a sequence to confirm the basic operation of the instrument. It should be performed after receiving the instrument. It is a useful learning exercise as well.

Before proceeding with this procedure, finish reading this instruction manual thoroughly. Then read the “Local Control” section of the “Programming Manual for -B Instruments” thoroughly. The “Local Control” section describes the front panel controls used in this operational check - in particular, the MOVE, CHANGE, and ADJUST controls.

1. Connect the pulser, the load, and the oscilloscope as described in the preceding “Basic Test Arrangement” section. Install a DUT.

 Confirm that the scope probe, test load, cables, and any adapters used are rated for 1.5 kV pulsed operation.

2. Turn on the AVRQ-2-B-PN-EVE / AVRQ-3-B. The main menu will appear on the LCD.
3. To set the AVRQ-2-B-PN-EVE / AVRQ-3-B to trigger from the internal clock at a PRF of 10 Hz:
 - a) The arrow pointer should be pointing at the frequency menu item. If it is not, press the MOVE button until it is.
 - b) Press the CHANGE button. The frequency submenu will appear. Rotate the ADJUST knob until the frequency is set at 10 Hz.
 - c) The arrow pointer should be pointing at the “Internal” choice. If it is not, press MOVE until it is.
 - d) Press CHANGE to return to the main menu.
4. To set the delay to 50 ns:
 - a) Press the MOVE button until the arrow pointer is pointing at the delay menu item.
 - b) Press the CHANGE button. The delay submenu will appear. Rotate the ADJUST knob until the delay is set at 50 ns.
 - c) The arrow pointer should be pointing at the “Normal” choice. If it is not, press MOVE until it is.

- d) Press CHANGE to return to the main menu.
5. To set the rise time to 100 ns:
 - a) Press the MOVE button until the arrow pointer is pointing at the rise time menu item.
 - b) Press the CHANGE button. The rise time submenu will appear. Rotate the ADJUST knob until the rise time is set at 100 ns.
 - c) Press CHANGE to return to the main menu.
 6. To set the HV PULSE amplitude to +1 kV:
 - a) Press the MOVE button until the arrow pointer is pointing at the AMP1 menu item.
 - b) Press the CHANGE button. The submenu will appear. Rotate the ADJUST knob until the rise time is set at + 1 kV.
 - c) Press CHANGE to return to the main menu.
 7. To set the VCC amplitude to +5V:
 - a) Press the MOVE button until the arrow pointer is pointing at the AMP2 menu item.
 - b) Press the CHANGE button. The submenu will appear. Rotate the ADJUST knob until the rise time is set at +5V.
 - c) Press CHANGE to return to the main menu.
 8. To set the LED bias current +7.5 mA:
 - a) Press the MOVE button until the arrow pointer is pointing at the OS2 menu item.
 - b) Press the CHANGE button. The submenu will appear. Rotate the ADJUST knob until the rise time is set at +7.5 mA.
 - c) Press CHANGE to return to the main menu.
 9. To set the load resistance amplitude to 1000 Ohms:
 - a) Press the MOVE button until the arrow pointer is pointing at the RES menu item.

- b) Press the CHANGE button. The submenu will appear. Rotate the ADJUST knob until the rise time is set at 1000 Ohms.
 - c) Press CHANGE to return to the main menu.
10. At this point, nothing should appear on the oscilloscope.
11. To enable the output:
- a) Press the MOVE button until the arrow pointer is pointing at the output menu item.
 - b) Press the CHANGE button. The output submenu will appear.
 - c) Press MOVE until the arrow pointer is pointing at the "ON" choice.
 - d) Observe the oscilloscope. You should see -1.5 kV pulses with 100 ns rise time, approximately.
 - e) Press CHANGE to return to the main menu.
12. Try varying the rise time, by repeating step (5). As you rotate the ADJUST knob, the rise time on the oscilloscope will change.
13. 90 seconds after the last parameter change, the instrument will automatically shut the output off. Confirm that this occurs.

This completes the operational check.

PROTECTING YOUR INSTRUMENT

USE HIGH-VOLTAGE CABLES, CONNECTORS, AND PROBES

 Confirm that the scope probe, test load, cables, and any adapters used are rated for 2 kV pulsed operation.

SHORT-CIRCUIT PROTECTION

The output will withstand temporary short-circuit conditions. However, short-circuit conditions should not be allowed to persist longer than 10 seconds, or the stress on the components will shorten the circuit lifetime.

MECHANICAL INFORMATION

TOP COVER REMOVAL

If necessary, the interior of the instrument may be accessed by removing the four Phillips screws on the top panel. With the four screws removed, the top cover may be slid back (and off).

Always disconnect the power cord before opening the instrument.

There are no user-adjustable internal circuits. For repairs other than fuse replacement, please contact Avtech (info@avtechpulse.com) to arrange for the instrument to be returned to the factory for repair.

 Caution: High voltages (over 1500V) are present inside the instrument during normal operation. Do not operate the instrument with the cover removed.

 Caution: Do not remove the internal aluminum lid. It shields certain very-high-voltage areas.

RACK MOUNTING

A rack mounting kit is available. The -R5 rack mount kit may be installed after first removing the one Phillips screw on the side panel adjacent to the front handle.

MAINTENANCE

REGULAR MAINTENANCE

This instrument does not require any regular maintenance.

On occasion, one or more of the four rear-panel fuses may require replacement. All fuses can be accessed from the rear panel. See the “FUSES” section for details.

CLEANING

If desired, the interior of the instrument may be cleaned using compressed air to dislodge any accumulated dust. (See the “TOP COVER REMOVAL” section for instructions on accessing the interior.) No other cleaning is recommended.

PROGRAMMING YOUR PULSE GENERATOR

KEY PROGRAMMING COMMANDS

The “Programming Manual for -B Instruments” describes in detail how to connect the pulse generator to your computer, and the programming commands themselves. A large number of commands are available; however, normally you will only need a few of these. Here is a basic sample sequence of commands that might be sent to the instrument after power-up:

*rst	(resets the instrument)
trigger:source internal	(selects internal triggering)
frequency 10 Hz	(sets the frequency to 10 Hz)
pulse:transition 50 ns	(sets the rise time to 50 ns)
pulse:delay 1 us	(sets the delay to 100 ns)
volt1 +1 kV	(sets the HV PULSE amplitude to +1 kV)
volt2 5.0	(sets VCC to +5.0V)
curr:low2 10 mA	(sets the LED bias to 10 mA)
output:impedance 350	(sets the logic load impedance to 350 Ohms)
output on	(turns on the output)

The output will turn off automatically 90 seconds later, if no further commands are sent before then.

For triggering a single event, this sequence would be more appropriate:

*rst	(resets the instrument)
trigger:source hold	(turns off all triggering)
pulse:transition 50 ns	(sets the rise time to 1 us)
volt1 +1 kV	(sets the HV PULSE amplitude to +1 kV)
volt2 5.0	(sets VCC to +5.0V)
curr:low2 10 mA	(sets the LED bias to 10 mA)
output:impedance 350	(sets the logic load impedance to 350 Ohms)
output on	(turns on the output)
trigger:source immediate	(generates a single non-repetitive trigger event)
trigger:source hold	(turns off all triggering)
output off	(turns off the output)

To set the instrument to trigger from an external TTL signal applied to the rear-panel TRIG connector, use:

*rst	(resets the instrument)
trigger:source external	(selects external triggering)
pulse:transition 50 ns	(sets the rise time to 50 ns)
pulse:delay 1 us	(sets the delay to 100 ns)
volt1 +1 kV	(sets the HV PULSE amplitude to +1 kV)

volt2 5.0	(sets VCC to +5.0V)
curr:low2 10 mA	(sets the LED bias to 10 mA)
output:impedance 350	(sets the logic load impedance to 350 Ohms)
output on	(turns on the output)

These commands will satisfy 90% of your programming needs.

ALL PROGRAMMING COMMANDS

For more advanced programmers, a complete list of the available commands is given below. These commands are described in detail in the “Programming Manual for -B Instruments”. (Note: this manual also includes some commands that are not implemented in this instrument. They can be ignored.)

<u>Keyword</u>	<u>Parameter</u>	<u>Notes</u>
LOCAL		
OUTPut:		
:[STATe]	<boolean value>	
:PROTection		
:TRIPped?		[query only]
REMOTE		
[SOURce]:		
:FREQuency		
[:CW FIXed]	<numeric value>	
[SOURce]:		
:CURRent		
:LOW	<numeric value>	
:PULSe		
:PERiod	<numeric value>	
:HOLD	WIDTh DCYCLe	
:DELay	<numeric value>	
:GATE		
:TYPE	ASYNc SYNc	
:LEVel	HIgh LOw	
:TRANsition		
:[LEADing]	<numeric value>	
:VOLTage		
[:LEVel]		
[:IMMediate]		
[:AMPLitude]	<numeric value> EXTeRnal	
STATUS:		
:OPERation		
:[EVENT]?		[query only, always returns "0"]
:CONDition?		[query only, always returns "0"]
:ENABle	<numeric value>	[implemented but not useful]
:QUESTionable		
:[EVENT]?		[query only, always returns "0"]
:CONDition?		[query only, always returns "0"]
:ENABle	<numeric value>	[implemented but not useful]
SYSTEM:		
:COMMunicate		
:GPIB		
:ADDReSS	<numeric value>	
:SERial		
:CONTRol		
:RTS	ON IBFull RFR	
:[RECEive]		
:BAUD	1200 2400 4800 9600	
:BITS	7 8	
:ECHO	<boolean value>	
:PARity		
:[TYPE]	EVEN ODD NONE	

	:SBITS	1 2	
:ERRor			
:[NEXT]?			[query only]
:COUNT?			[query only]
:VERSion?			[query only]
TRIGger:			
:SOURce		INTernal EXTernal MANual HOLD IMMEDIATE	[no query form]
*CLS			
*ESE		<numeric value>	
*ESR?			[query only]
*IDN?			[query only]
*OPC			
*SAV		0 1 2 3	[no query form]
*RCL		0 1 2 3	[no query form]
*RST			[no query form]
*SRE		<numeric value>	
*STB?			[query only]
*TST?			[query only]
*WAI			[no query form]

WIRING DIAGRAMS

WIRING OF AC POWER

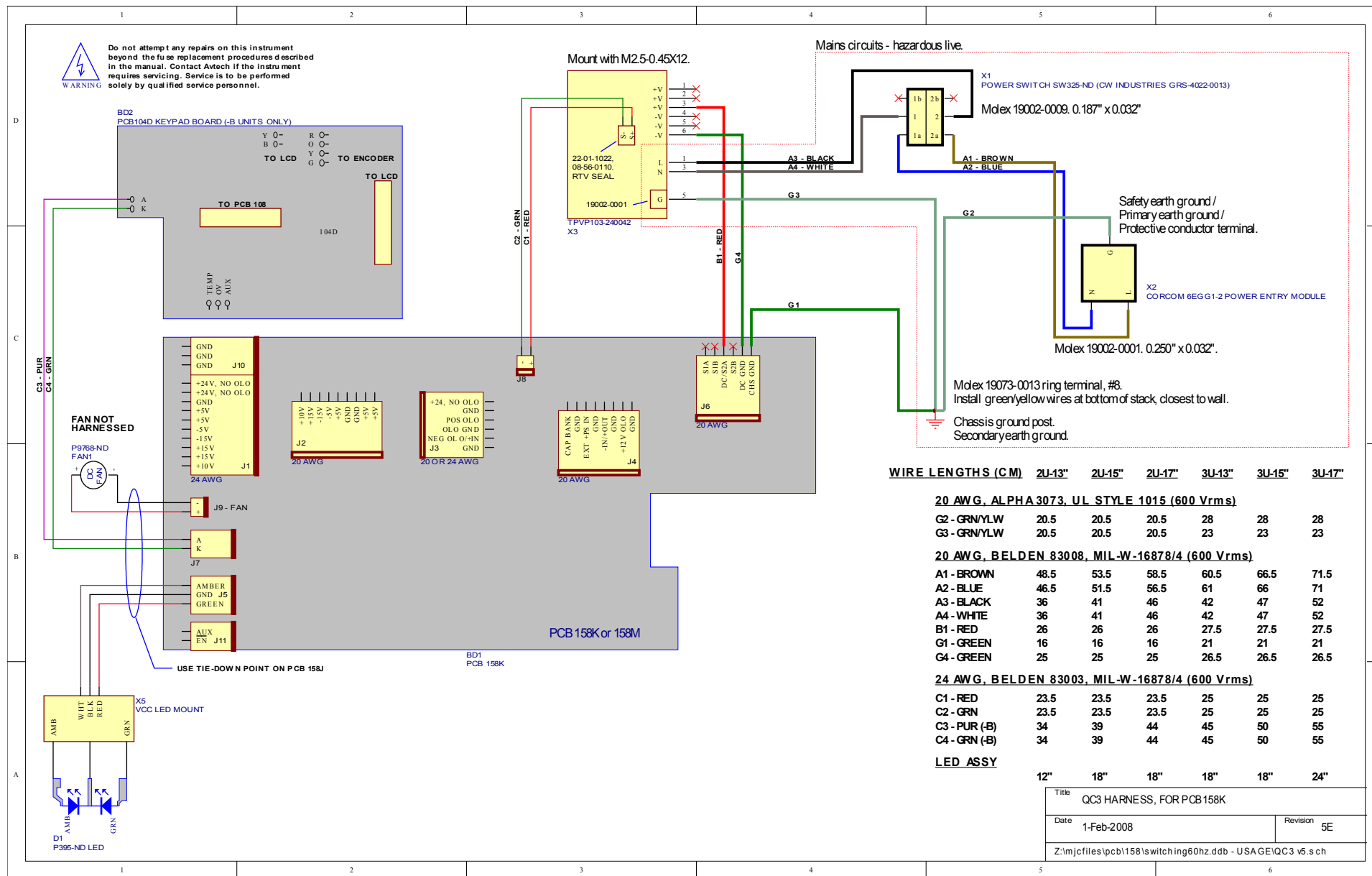

PCB 158M - LOW VOLTAGE POWER SUPPLY, 1/3

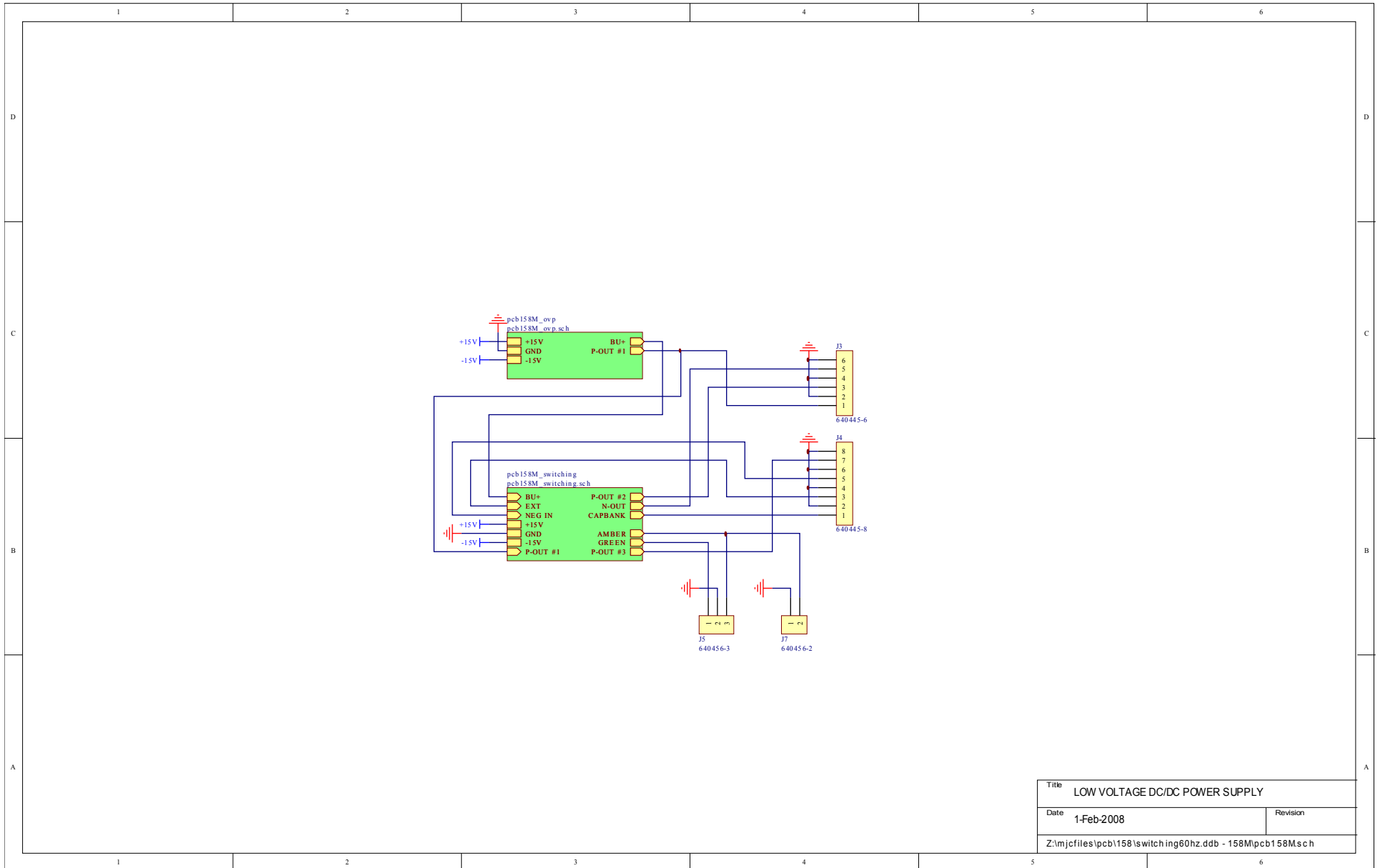

Title		LOW VOLTAGE DC/DC POWER SUPPLY
Date	1-Feb-2008	Revision
Z:\mjc\files\pcb158\switching60hz.ddb - 158M\pcb158M.sch		

PCB 158M - LOW VOLTAGE POWER SUPPLY, 2/3

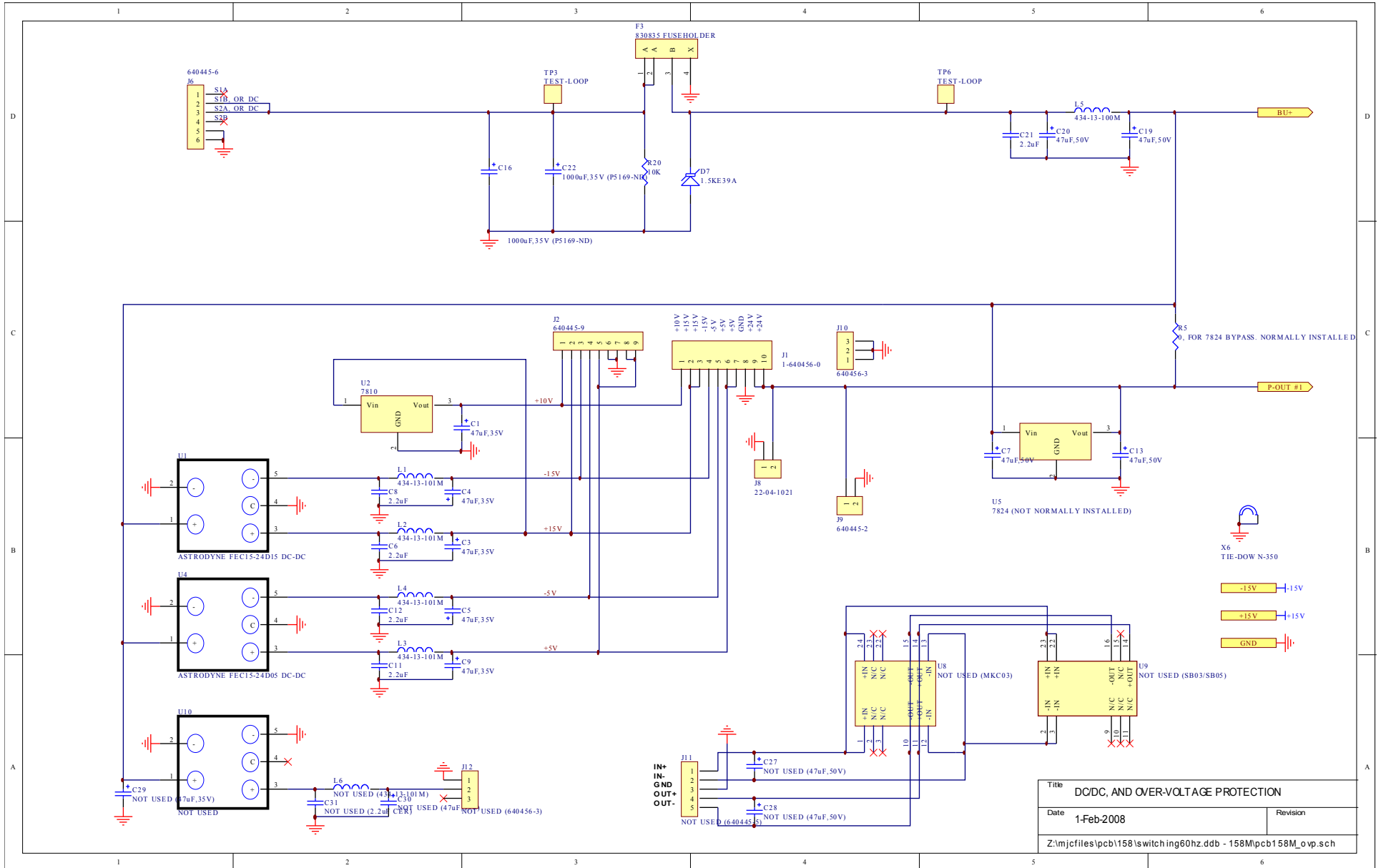

Title		DC/DC, AND OVER-VOLTAGE PROTECTION	
Date	1-Feb-2008	Revision	
Z:\mjc\files\pcb158\switching60hz.ddb - 158M\pcb158M_0vp.sch			

PCB 158M - LOW VOLTAGE POWER SUPPLY, 3/3

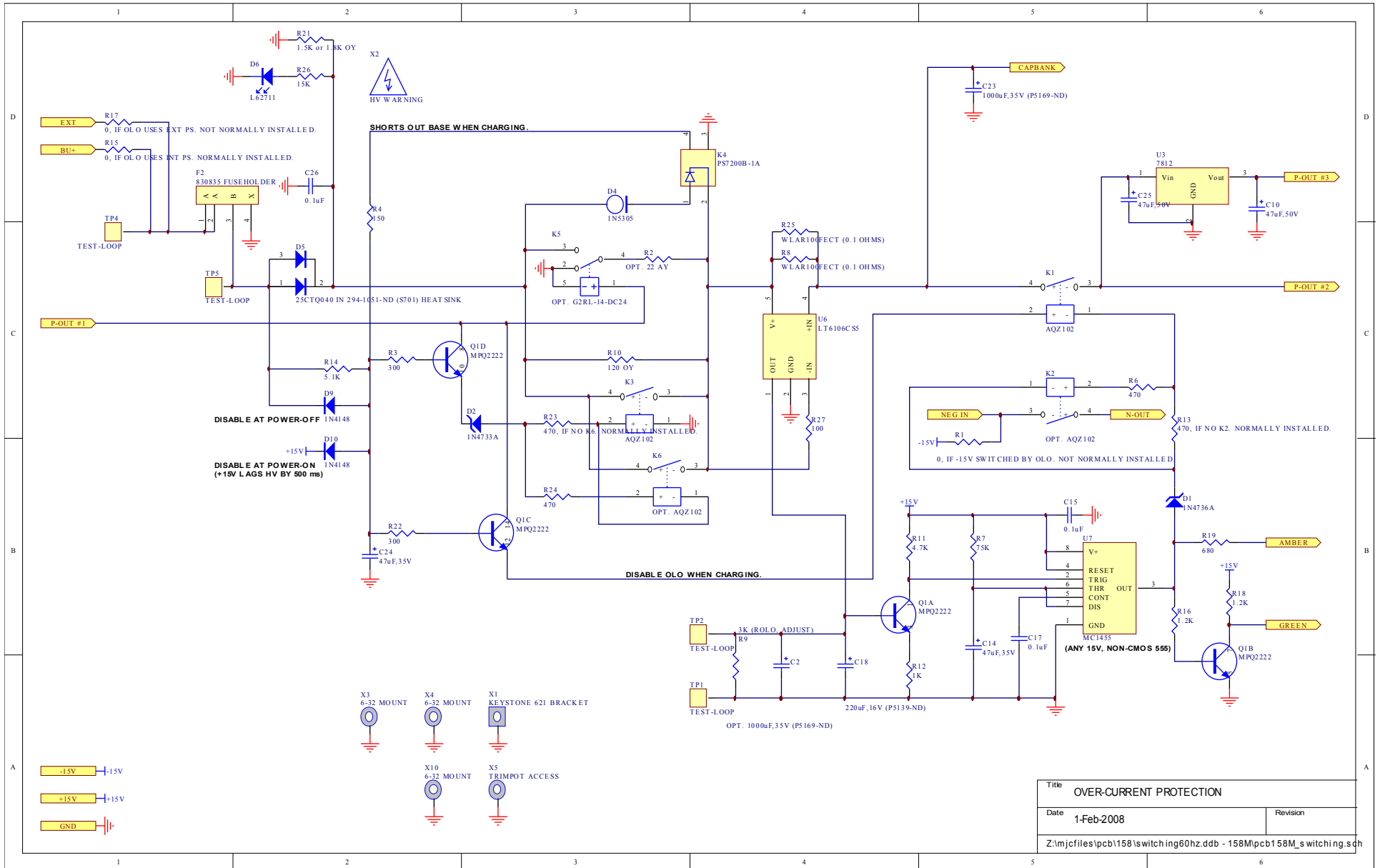

Title OVER-CURRENT PROTECTION	
Date 1-Feb-2008	Revision
Z:\mjc\files\pcb\158\switching60hz.ddb - 158Mpcb158M_switching.sch	

PCB 104D - KEYPAD / DISPLAY BOARD, 1/3

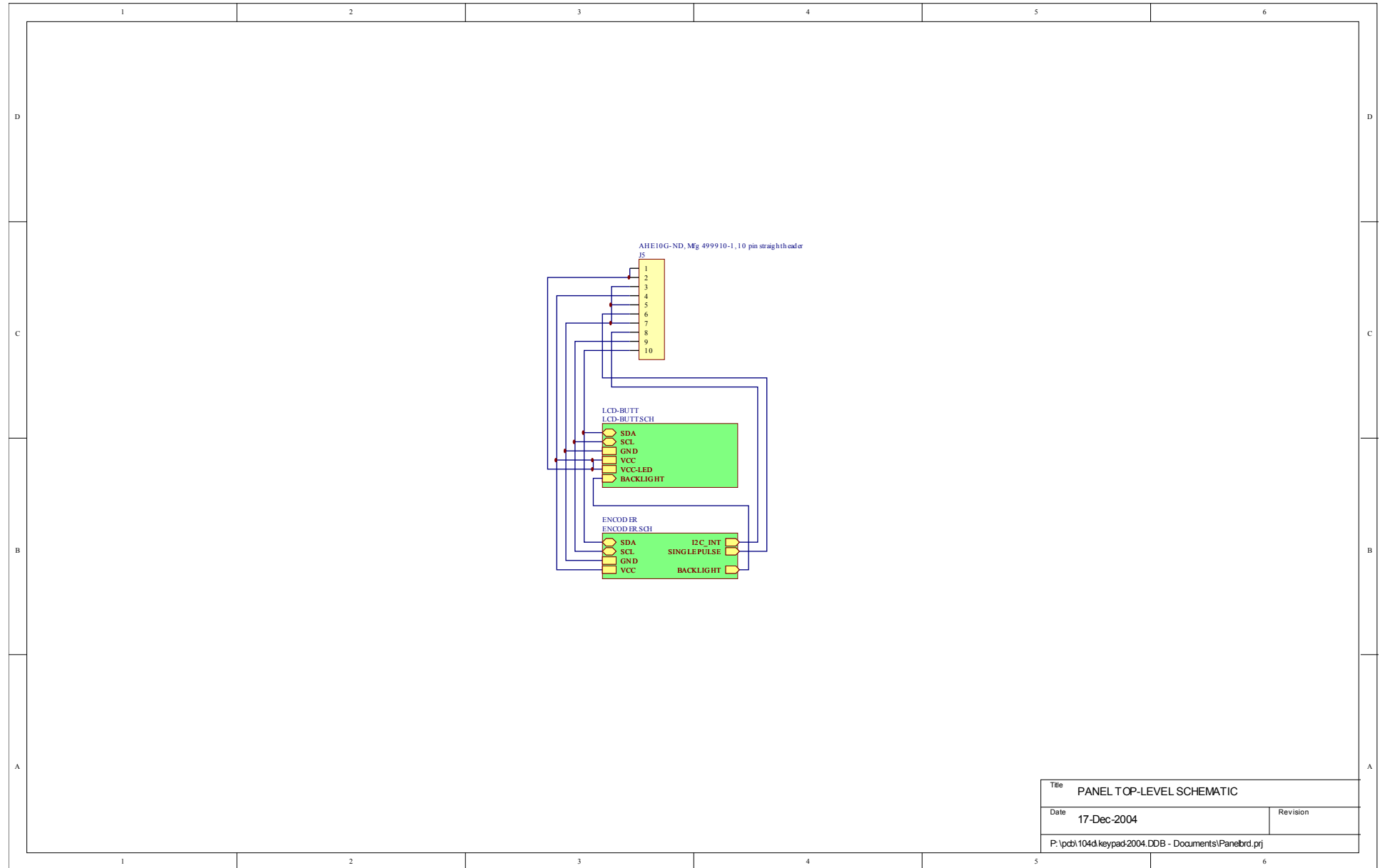

Title		PANEL TOP-LEVEL SCHEMATIC	
Date	17-Dec-2004	Revision	
P:\pcb\104d\keypad-2004.DDB - Documents\Panelbrd.prj			

PCB 104D - KEYPAD / DISPLAY BOARD, 2/3

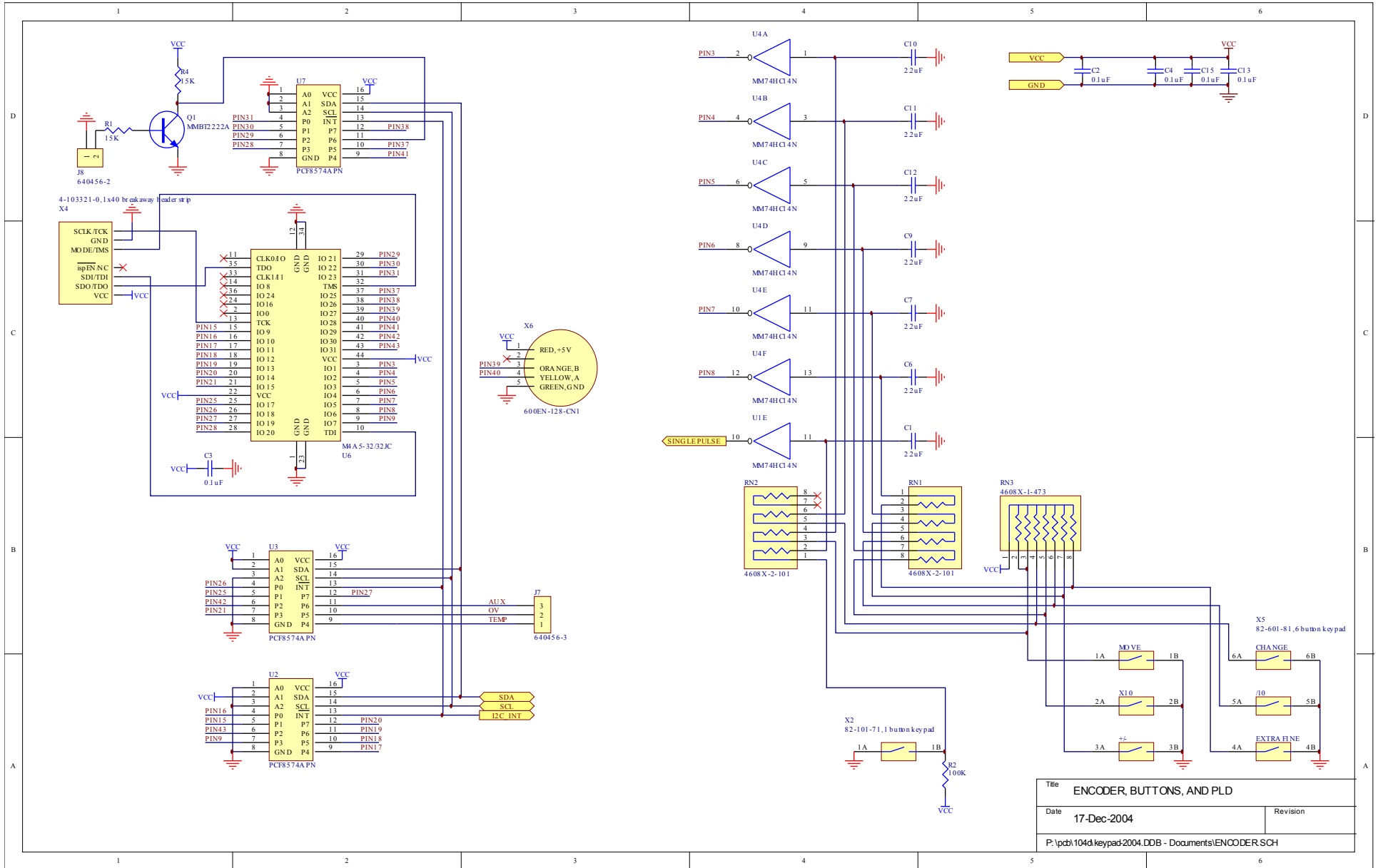

PCB 104D - KEYPAD / DISPLAY BOARD, 3/3

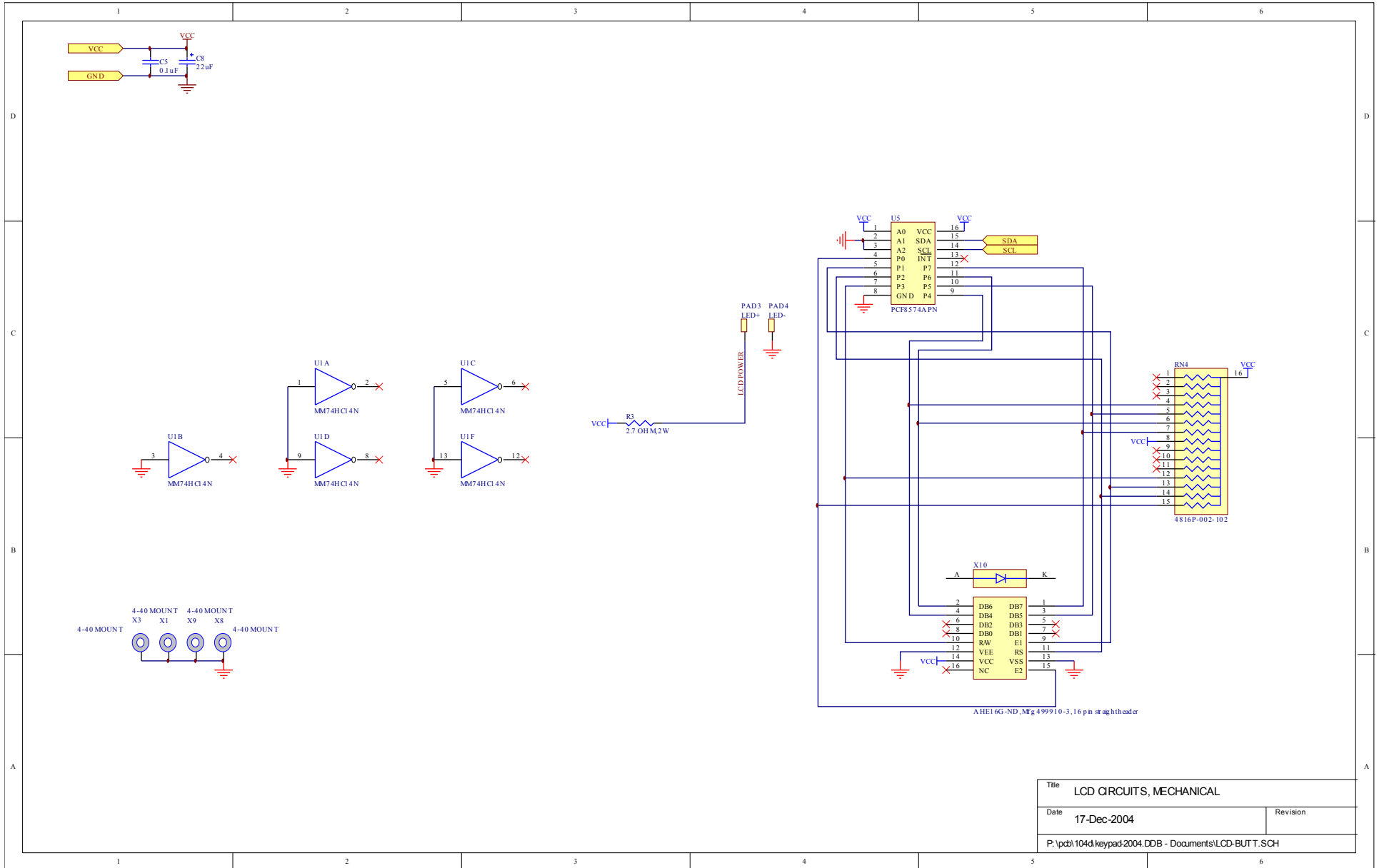

Title		LCD CIRCUITS, MECHANICAL	
Date	17-Dec-2004	Revision	
P:\pcb\104d\keypad-2004.DDB - Documents\LCD-BUTT.SCH			

DUT WIRING

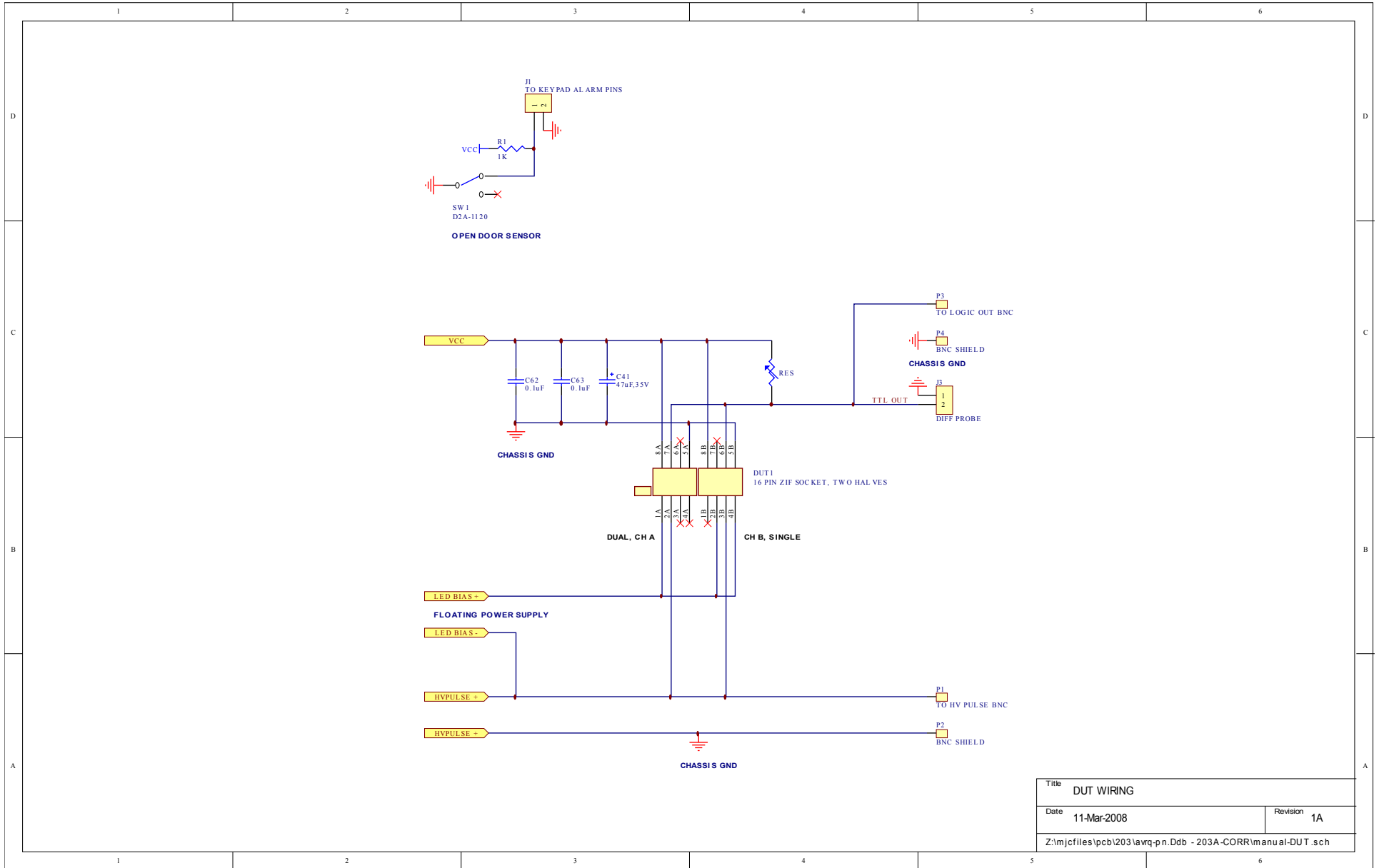

Title	DUT WIRING	
Date	11-Mar-2008	Revision 1A
Z:\mjc\files\pcb\203\avq-p.n.Ddb - 203A-CORR\manual-DUT.sch		

MAIN WIRING

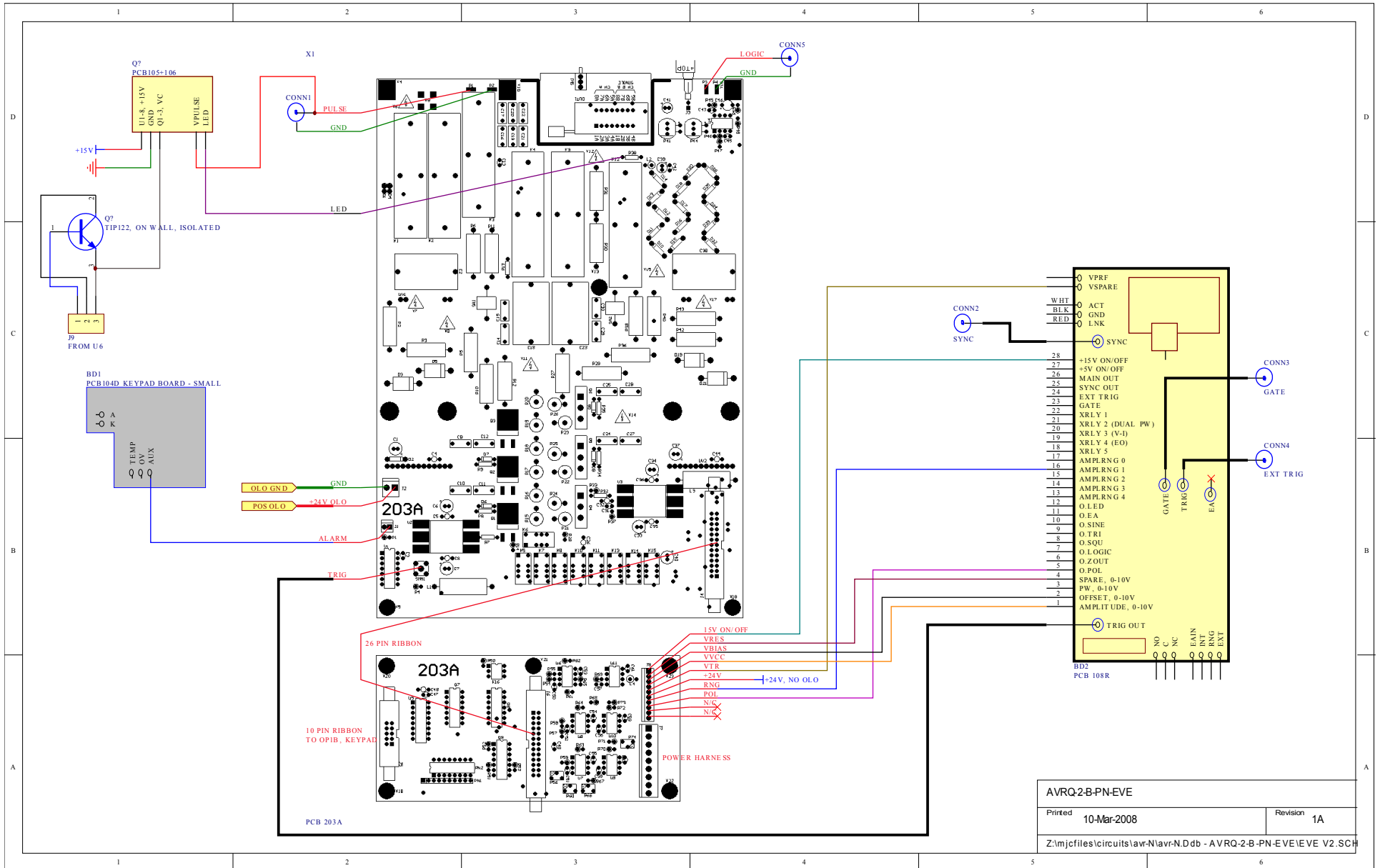

PERFORMANCE CHECK SHEET